

7000FM  
GFC IR ANALYSER  
OPERATING MANUAL

The Signal Instrument Company Limited  
12 Doman Road, Camberley  
Surrey, GU15 3DF  
England

Tel: +44 (0) 1276 682841

Fax: +44 (0) 1276 691302

Part Number 338050

## DOCUMENT HISTORY

ISSUE	AMENDMENT	DATE
1.00	First Published	27/10/98

**© The Signal Instrument Co. Ltd.**

All rights reserved. No part of this manual may be reproduced, stored in a retrieval system or transmitted in any form or by any means - electronic, mechanical, photocopying, recording or otherwise - without the prior written permission of The Signal Instrument Co. Ltd.

While we believe that the information and guidance given in this manual is correct, all parties must rely upon their own skill and judgement when making use of it. The Signal Instrument Co. Ltd. will not assume any liability to anyone for any loss or damage caused by any error or omission in the manual, whether such error or omission is the result of negligence or any other cause. Any and all such liability is disclaimed.

---

# CONTENTS

<b>1. INTRODUCTION .....</b>	<b>8</b>
1.1 Analyser .....	8
1.2 Applications.....	8
1.3 Getting Started.....	8
1.4 Special Requirements.....	8
<b>2. SPECIFICATION .....</b>	<b>9</b>
2.1 Accessories.....	9
2.2 Accuracy and Repeatability .....	9
2.3 Ambient Pressure Effect.....	9
2.4 Ambient Temperature Effect.....	9
2.5 Analogue Outputs .....	9
2.6 Bypass Flow Sensitivity.....	10
2.7 Detector .....	10
2.8 Detector Noise.....	10
2.9 Digital Inputs .....	10
2.10 Digital Outputs .....	10
2.11 Dimensions.....	10
2.12 Display .....	11
2.13 Drift.....	11
2.14 Environment.....	11
2.15 Fault Relay.....	11
2.16 Linearity.....	11
2.17 Options .....	11
2.18 Pneumatics .....	11
2.19 Power.....	12
2.20 Pump Control Output.....	12
2.21 Ranges .....	12
2.22 Response Time .....	12
2.23 Safety .....	12
2.24 Sample .....	13
2.25 Serial Interface .....	13
2.26 Warm-up Time .....	13
<b>3. INSTALLATION.....</b>	<b>14</b>
3.1 Introduction .....	14
3.2 Analyser Location.....	14
3.3 Rack Mounting.....	14
3.4 Mains Power Connections.....	15
3.5 Gas Connections .....	15
3.6 Chart Connections .....	17
3.7 Remote Connections.....	18
3.8 RS232 Connection .....	19
<b>4. BASIC OPERATION .....</b>	<b>20</b>
4.1 Introduction .....	20
4.2 Installation.....	20
4.3 Operation.....	20
4.4 Shut-down .....	21
<b>5. OPERATION .....</b>	<b>22</b>
5.1 Introduction .....	22
5.2 Analyser Basics.....	22

5.3 Manual Operation .....	22
5.4 Primary Screen .....	23
5.5 Key Protection .....	25
5.6 Second Display Screen .....	25
5.7 Manual Range Selection .....	25
5.8 Automatic Range Selection .....	25
5.9 Calibration .....	26
5.10 Password Protection .....	27
5.11 Interrogation Instructions .....	27
5.12 Configuration .....	29
5.13 LCD Optimisation .....	32
5.14 Fault Relay .....	32
5.15 Converting to Other Units .....	33
<b>6. ANALYSER CONTROLS .....</b>	<b>34</b>
6.1 Front Panel Controls .....	34
6.2 Introduction .....	34
6.3 Hard Keys .....	35
6.4 Primary Soft Keys .....	35
6.5 Set Functions .....	36
<b>7. LOGIC REMOTE CONTROL .....</b>	<b>43</b>
7.1 Description .....	43
7.2 Range Control and Indication .....	44
7.3 Gas Path Control and Indication .....	44
7.4 Analyser Mode Control and Indication .....	44
7.5 Calibration Control and Indication .....	44
7.6 Concentration Alarms .....	45
7.7 Sleep Mode Control .....	45
7.8 Fault Relay .....	45
<b>8. SERIAL PORT REMOTE CONTROL .....</b>	<b>46</b>
8.1 Description .....	46
8.2 General Packet Format .....	47
8.3 AK Command Packet .....	47
8.4 AK Acknowledgement Packet .....	47
8.5 AK Codes .....	48
<b>9. FAULT CODES .....</b>	<b>54</b>
9.1 Information .....	54
9.2 Self Check .....	54
9.3 Health Check .....	55
<b>10. TECHNICAL DESCRIPTION .....</b>	<b>57</b>
10.1 Principle of Operation .....	57
10.2 Sample System .....	57
10.3 Flow Control .....	58
10.4 Electronics .....	58
10.5 User Interface .....	59
<b>11. ROUTINE MAINTENANCE .....</b>	<b>60</b>
11.1 Introduction .....	60
11.2 Calibration .....	60
11.3 Password Release .....	60
<b>12. ROUTINE SERVICING .....</b>	<b>61</b>

12.1 Policy.....	61
<b>13. WARRANTY .....</b>	<b>62</b>

## Tables

Table 1 Chart Output Functions .....	17
Table 2 Range Output Voltages .....	17
Table 3 Calibration Types .....	26
Table 4 Calibration Results.....	28
Table 5 Converting to Other Units .....	33
Table 6 Calibration Types .....	36
Table 7 Logic Levels .....	43
Table 8 Range Control Logic .....	44
Table 9 Gas Path Control Logic.....	44
Table 10 Calibration Types.....	44
Table 11 Gas Number Cross-Reference .....	50
Table 12 Model Number Cross-Reference .....	50

## Figures

Figure 1 Figure 1 Electrical & Pneumatic Connections .....	15
Figure 2 Tube Fitting Assembly.....	16
Figure 3 Remote Connections.....	17
Figure 4 Chart Pin Allocations .....	17
Figure 5 Typical Remote Logic Connections .....	18
Figure 6 RS232 Connection.....	19
Figure 7 LCD Contrast Control .....	32
Figure 8 Front Panel Controls.....	34
Figure 9 Flow Schematic Single Range Analyser .....	57
Figure 10 Flow Schematic Dual Range (Series) Analyser.....	57
Figure 11 Flow Schematic Dual Range (Alternate) Analyser .....	58



# 1. INTRODUCTION

## 1.1 Analyser

- 1.1.1 The analyser uses a well-established infra-red gas filter correlation technique using gas-filled optical filters for maximum selectivity. A single beam optical path increases tolerance to contamination.
- 1.1.2 A new dimension in operational simplicity has been added by the use of a microprocessor controlled LCD dot matrix display and interactive function keys. Automatic fault free start-up and a purged shut-down feature minimise operator error and allow unattended use.

## 1.2 Applications

- 1.2.1 The main applications for this analyser are with automobile combustion research, power station and boiler combustion research, combustion consultants, and HSE compliance testing.
- 1.2.2 The analyser is of 3U height and is therefore equally convenient on the laboratory bench, in a 19" rack, or when used as a portable site trial measurement tool.

## 1.3 Getting Started

- 1.3.1 Installation.
  - 1.3.1.1 Unless you are familiar with the installation of gas analysers, we recommend that you read the INSTALLATION section up to and including 3.5.
- 1.3.2 Operation
  - 1.3.2.1 Read all of section 4 (BASIC OPERATION) and follow the instructions. This will take you through a step-by-step sequence to allow the measurement of your sample gas. Read section 5 (OPERATION) to learn about all the analyser functions.
- 1.3.3 Configuration
  - 1.3.3.1 Read section 6.5.1 in ANALYSER CONTROLS for basic instructions on the configuration syntax, then continue with that section for individual parameter information.
- 1.3.4 Maintenance
  - 1.3.4.1 Read ROUTINE MAINTENANCE section 11 to keep your analyser in first class condition.

## 1.4 Special Requirements

- 1.4.1 The sample must have a dew point at least 10 °C below the local ambient temperature. If your sample is hot and/or wet, use one of our 200 series cooler driers to reduce the temperature and water content.
- 1.4.2 You will also require calibration gases. Use pure Nitrogen to set the zero point. Use a dilution of span gas in Nitrogen to set the span point.
- 1.4.3 The analyser requires a constant supply of Nitrogen to the Zero port for correct operation.



## 2. SPECIFICATION

### 2.1 Accessories

- 2.1.1 Chart recorder cables for voltage or current output.
- 2.1.2 RS232 cables to suit both 9 and 25 way connectors.

### 2.2 Accuracy and Repeatability

- 2.2.1 Better than  $\pm 1$  % of range or  $\pm 0.5$  ppm whichever is greater.

### 2.3 Ambient Pressure Effect

- 2.3.1 Output is directly proportional to absolute barometric pressure (measured at EXHAUST port).

### 2.4 Ambient Temperature Effect

- 2.4.1 Zero
  - 2.4.1.1 CO<sub>2</sub> :  $\pm 0.2$  %/ $^{\circ}$ C of highest range.
  - 2.4.1.2 CO :  $\pm 0.2$  %/ $^{\circ}$ C of 1000 ppm and lower ranges and
  - 2.4.1.3 CO :  $\pm 0.2$  %/ $^{\circ}$ C of 10 % and lower ranges.
- 2.4.2 Span
  - 2.4.2.1 Less than  $\pm 0.35$  % of range from 5  $^{\circ}$ C to 30  $^{\circ}$ C.
- 2.4.3 Chart Recorder Output
  - 2.4.3.1 Add  $\pm 0.02$  % of range per  $^{\circ}$ C.

### 2.5 Analogue Outputs

- 2.5.1 Voltage
  - 2.5.1.1 Non-isolated 0 - 10 Vdc representing selected range with  $\pm 15$  % over-range (-1.5 Vdc to 11.5 Vdc).
  - 2.5.1.2 Lowest load resistor 2 k $\Omega$ .
  - 2.5.1.3 Continuous short circuit allowed. Recovery < 15 min.
- 2.5.2 Current
  - 2.5.2.1 Isolated 4 - 20 mAdc representing selected range with  $\pm 15$  % over-range (1.6 mAdc to 22.4 mAdc).
  - 2.5.2.2 Highest loop resistance 600  $\Omega$  including cable and any current sense resistor.
  - 2.5.2.3 Continuous open circuit allowed. Recovery < 2 min.
- 2.5.3 Range Indication
  - 2.5.3.1 Non-isolated 0 - 8 Vdc representing the selected range number.
  - 2.5.3.2 Ranges are numbered from 1 (most sensitive) to 8 (least sensitive) and the output changes by approximately 1 Vdc for each range step. The actual number of ranges used, and therefore indicated, depends on the analyser.
  - 2.5.3.3 Loss of mains power, or a disconnected signal cable, is indicated by a measured output of 0 Vdc.
  - 2.5.3.4 Lowest load resistor 2 k $\Omega$ .

2.5.3.5 Continuous short circuit allowed. Recovery < 15 min.

## 2.6 Bypass Flow Sensitivity

2.6.1 Less than  $\pm 1$  % change in reading from 0.2 to 2 l/min into ambient pressure exhaust.

## 2.7 Detector

2.7.1 Gas filter correlation, non dispersive infra-red with solid state detector.

## 2.8 Detector Noise

2.8.1 Zero noise less than 1% of range with time constant of 2.0 seconds.

2.8.2 Span noise less than 1% of range with time constant of 2.0 seconds

2.8.3 Range time constants can be configured to suit application sample noise. Longer time constants will reduce noise at the expense of response time.

## 2.9 Digital Inputs

2.9.1 Digital control lines are provided for the remote control of Range, Input Port, Sleep (Standby), and Calibration. The inputs are arranged for contact closure to Common Return to represent the TRUE condition. This is sometimes referred to as "Negative Logic". All voltage levels are with respect to the Common Return line.

2.9.2 Absolute maximum (most positive) input +5.0 Vdc.

2.9.3 Absolute minimum (most negative) input -0.0 Vdc.

2.9.4 Logic 1 (TRUE) level <1.2 Vdc.

2.9.5 Logic 0 (FALSE) level > 3.7 Vdc.

## 2.10 Digital Outputs

2.10.1 Digital lines are provided for the remote indication of the analyser status. Range, Input Port, Calibration in Progress, Calibration Failed, High Alarm, and Low Alarm are available.

2.10.2 Voltage must not be applied to these outputs. Continuous short circuit to Common Return is allowed.

2.10.3 Logic 1 (TRUE) level < 1 Vdc at 5 mAdc sink to Common Return.

2.10.4 Logic 0 (FALSE) level from a nominal +5 Vdc via a 1 k $\Omega$  resistor.

## 2.11 Dimensions

2.11.1 Analyser

2.11.1.1 Rack or bench mounting 3U high.

2.11.1.2 Depth behind mounting face 550 mm.

2.11.1.3 Protrusion in front of mounting face 45 mm.

2.11.1.4 Weight approx.13 kg.

**2.12 Display**

- 2.12.1 240 x 64 pixel LCD display with switchable back-light shows concentration units and gas in large, clear characters
- 2.12.2 Vertical bar graph of chart output with alarm markers.
- 2.12.3 Sample flow indication.
- 2.12.4 Range, control, and message areas.
- 2.12.5 Multi-screen operation provides full analyser status and configuration facilities.

**2.13 Drift**

- 2.13.1 Zero drift less than 1% of range in 1 hour at constant temperature and pressure.
- 2.13.2 Span drift less than 1% of range in 1 hour at constant temperature and pressure.

**2.14 Environment**

- 2.14.1 Ambient Temperature 5 °C to 35 °C.
- 2.14.2 Dew Point at least 10 °C less than local ambient temperature.
- 2.14.3 Keep out of direct sunlight, away from sources of radiant heat, and clear of drafts.

**2.15 Fault Relay**

- 2.15.1 Volt-free single pole changeover relay with the de-energised state indicating the fault condition.
- 2.15.2 Contact ratings are 1 A at 50 Vdc.
- 2.15.3 Isolation > 10 MΩ at 50 Vdc.

**2.16 Linearity**

- 2.16.1 Better than ±0.5 % of range.

**2.17 Options**

- 2.17.1 With or without an internal sample pump.

**2.18 Pneumatics**

- 2.18.1 Sample connections use 1/4" (6.35 mm) tube and fittings. Inlet pressure -5 psi(-0.345 bar, -34.5 kPa) with pump to 7 psi (0.483 bar, 48.3 kPa). Flow rate 0 - 2 l/min.
- 2.18.2 Span and Zero connections use 1/4" (6.35 mm) tube and fittings. Inlet pressure -5 psi (-0.345 bar, 34.5 kPa) with pump to 7 psi (0.483 bar, 48.3 kPa). Flow rate 0 - 2 l/min.
- 2.18.3 Exhaust(s) use 1/4" tube and fittings. Do not obstruct or pressurise the exhaust port. Exhaust lines should have a minimum bore equivalent to thin walled 1/4" PTFE tube. For dual range analysers with dual exhaust ports, two separate exhaust lines are required, and these should not be commoned less than 1 metre from the analyser.

## 2.19 Power

- 2.19.1 Switchable between 115 Vac and 230 Vac  $\pm 15\%$ , 50 Hz and 60 Hz compatible.
- 2.19.2 Maximum power consumption 200 VA during warm up.
- 2.19.3 Fuse rating 6.3 A (115 Vac) or 3.15 A (230 Vac). Fuse type 'T' (HBC).
- 2.19.4 Fused IEC 320 plug on rear panel accepts IEC 320 sockets for USA and related territories.
- 2.19.5 Dual fused IEC 320 plug on rear panel accepts IEC 320 sockets for Europe, UK, Ireland, Cyprus, Malta, and Gibraltar.

## 2.20 Pump Control Output

- 2.20.1 0 - 24 Vdc output for direct connection to the Pump Control Adaptor. Short circuit allowed for up to 5 mins. Short circuit current < 70 mAdc.
- 2.20.2 Can be used to drive the input to most Solid State Relays for control of a remote pump.

## 2.21 Ranges

- 2.21.1 A 100/500/1000 ppm
- 2.21.2 B 1000/5000/10000 ppm
- 2.21.3 C 1/5/10 %
- 2.21.4 D 5/10/20 %
- 2.21.5 E 25/50/100 %
- 2.21.6 A + B DUAL
- 2.21.7 A + C DUAL
- 2.21.8 A + D DUAL
- 2.21.9 A + E DUAL
- 2.21.10 B + C DUAL
- 2.21.11 B + D DUAL
- 2.21.12 B + E DUAL

## 2.22 Response Time

- 2.22.1 Less than 15 s (5 % to 95 %) at 1 l/min flow, with 2.0 second time constants.

## 2.23 Safety

- 2.23.1 The analyser has been constructed in accordance with prescribed safety standards. All hazardous circuits are shielded.

**2.24 Sample**

- 2.24.1 The sample gas temperature must not exceed 40 °C and must have a dew point at least 10 °C below local ambient temperature.

**2.25 Serial Interface**

- 2.25.1 RS232C serial interface using 'AK' protocol provides full remote control and reporting facilities.
- 2.25.2 Baud rate can be set to 1200, 2400, 4800, 9600, or 19200.
- 2.25.3 Parity can be set to none, even, or odd.
- 2.25.4 Data bits can be set to 7 or 8.
- 2.25.5 Stop bits can be set to 1 or 2.
- 2.25.6 XON/XOFF control can be set on or off.
- 2.25.7 Factory set to 9600 Baud, no parity, 8 data bits, 1 stop bit, XON/XOFF enabled.

**2.26 Warm-up Time**

- 2.26.1 Usable in 2 min. Full accuracy in 1 hr.

### 3. INSTALLATION

#### **CAUTION**

THE ANALYSER MUST NOT BE USED WITHOUT A SAFETY EARTH CONNECTION.

THE SENSOR CAN BE AFFECTED BY MOISTURE AND PARTICULATE. USE A COOLER/DRYER AND PARTICULATE FILTER TO PRE-CONDITION HOT SAMPLE GASES.

#### 3.1 Introduction

- 3.1.1 Installation requires the use of a tool set compatible with electrical and pneumatic skills. A suitable set of tools for a minimum installation consists of an electrician's flat bladed screwdriver for the mains connections, a sharp knife for cutting PTFE tubing, a  $\frac{9}{16}$ " (14.3 mm) A/F spanner for  $\frac{1}{4}$ " fittings, and an  $\frac{11}{16}$ " (17.5 mm) A/F spanner for  $\frac{3}{8}$ " fittings. Full installation of remote control, chart recorder, and other features will require the use of a soldering iron plus solder, wire cutters, wire strippers, small pliers, and a working knowledge of the equipment to be connected. Plumbing in stainless steel will require the use of pipe cutters and benders. We, or our local agents, can offer an installation service if you do not have the necessary skills.
- 3.1.2 Nearly all functions provided by the front panel can be mimicked by commands sent via the RS232 serial port. Connect the serial port to one of the ports on the host computer, or to the serial port of any PC having either 'Signal' or 'Custom' software to effect control. For those wishing to write their own software, section 8 defines the communication protocol and lists the commands available together with their parameters and responses. The 'AK' protocol is the preferred method of data-logging where a PC based system is available. The PC RS232 port may require customisation if the available analyser RS232 settings are not suitable for the PC or host computer.
- 3.1.3 Connections to analogue data-logging equipment or chart recorders are available on the CHART connector. Voltage and isolated current outputs are available. Consult the specification section 2 for load restrictions.
- 3.1.4 The pneumatic and electrical connectors are found on the rear panel.

#### 3.2 Analyser Location

- 3.2.1 The analyser can be bench or rack mounted and should be placed in a dry and sheltered location out of direct sunlight, avoiding drafts, and protected from water ingress.
- 3.2.2 Observe the environmental limitations listed in the specification section.
- 3.2.3 The analyser relies on ventilation through the base, sides, top, and rear panel. Do not obstruct these areas. When mounting the analyser in a rack, a 1U gap must be left above and below the analyser. It may be necessary to provide air conditioning for a rack mounted system if it would cause the local ambient inside the rack to exceed the environmental limitations of the analyser.

#### 3.3 Rack Mounting

- 3.3.1 Unscrew the four feet and retain in a safe place prior to rack mounting. Plastic buttons on the outside edge of the base provide a 'gliding' surface when using rack supports.

### 3.4 Mains Power Connections

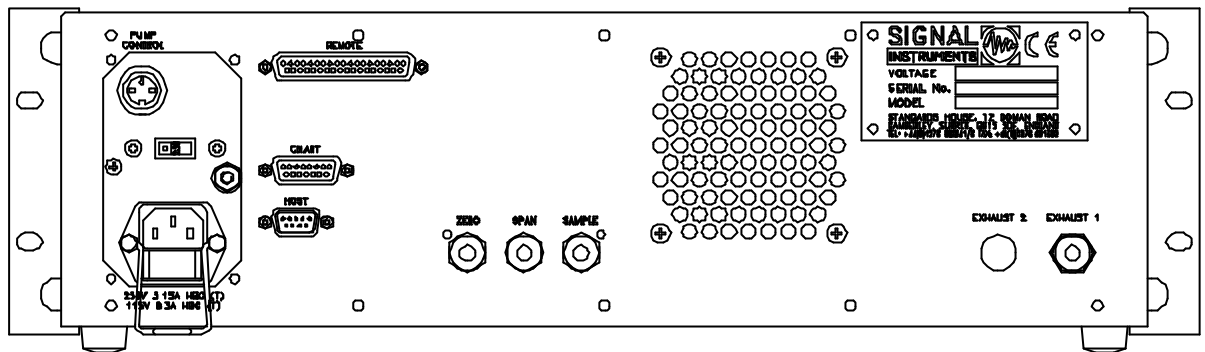

Figure 1 Figure 1 Electrical & Pneumatic Connections

#### 3.4.1 Wiring

3.4.1.1 All mains leads supplied with the analyser are colour coded and must be connected according to the following instructions to make the analyser safe for use.

3.4.1.1.1 Connect the BROWN wire to the LIVE (L) pin of the mains plug.

3.4.1.1.2 Connect the BLUE wire to the NEUTRAL (N) pin of the mains plug.

3.4.1.1.3 Connect the GREEN/YELLOW wire to the EARTH (E) pin of the mains plug.

#### 3.4.2 Analyser

3.4.2.1 The analyser is supplied with a 2 m long mains lead, with an IEC320 socket at one end for connection to the analyser. The other end should be connected to a mains plug to suit the local supply outlet.

3.4.2.2 Check the local mains voltage and set the Voltage Selector Switch on the rear panel to the 115 or 230 position according to the supply. See the analyser specification for allowed variations in mains supply.

3.4.2.3 Check that the fuse(s) fitted are suitable for your mains supply. 115 Vac requires 6.3 AT and 230 Vac requires 3.15 AT.

3.4.2.4 If your mains supply has no earth terminal, a separate earth must be connected to the M6 stud on the rear panel. This stud can also be used to provide a common ground or screen for remote control or data acquisition equipment. Consult a qualified electrician if you have no earth terminal at all.

#### 3.4.3 No Local Earth

3.4.3.1 If the local mains supply does not provide an earth connection, you must supply an independent one. Consult a qualified electrician.

3.4.3.2 A mains distribution panel should be installed to provide earthed power outlets for each item. You may wish to include extra facilities for data recording or computer facilities at the same time.

### 3.5 Gas Connections

3.5.1 The analyser is very sensitive to moisture condensation. Ensure that all gas inlets are from a dry and cool source. Although the analyser is fitted with an internal sample filter for sensor protection, an external filter is required to remove larger particulates.

3.5.2

**Figure 2 Tube Fitting Assembly**

All pipe fittings have the same assembly method. Cut the tubing to length ensuring that the ends are cut square. Slide the nut and ferrule over the tube. Insert the tube into the end of the fitting and hold it firmly against the internal shoulder. Slide the nut and ferrule to the fitting and tighten the nut until it is "finger tight". Tighten the nut a further 1/4 turns with a suitable spanner. When connections are remade, it is only necessary to tighten the nut slightly with the spanner after making it "finger tight". End inserts are necessary when using PTFE tubing to prevent buckling.

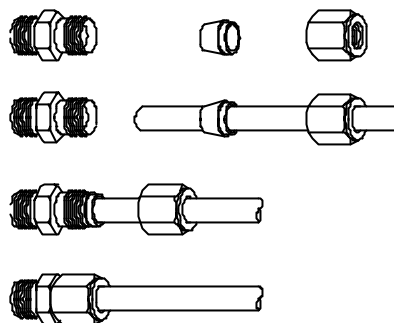

3.5.3

**Calibration Gases**

3.5.3.1

Calibration gases must use Nitrogen as their diluent.

3.5.4

**Span Calibration Gas**

3.5.4.1

You will require a source of span calibration gas. This should have a concentration of the span gas in a Nitrogen diluent with a value that falls within the calibration range of the analyser and be similar to the results you expect to be measuring. Fit a regulator capable of providing up to 15 psi (1.03 bar, 103 kPa) to a bottle of calibration gas. Connect the regulator to the analyser port labelled SPAN using 1/4" tubing. Ensure that the regulator and piping are clean and not contaminated. If the gas bottle is sited some distance from the analyser, make a note of the concentration value on the calibration certificate. You will need to configure the analyser using this value prior to calibration.

3.5.4.2

Flow is proportional to input pressure which should not exceed 7 psi (0.483 bar, 48.3 kPa).

3.5.5

**Zero Calibration Gas**

3.5.5.1

You will need a source of zero calibration gas.

3.5.5.2

Fit a regulator capable of providing up to 15 psi (1.03 bar, 103 kPa) to a bottle of zero calibration gas. Connect the regulator to the analyser port labelled ZERO using 1/4" tubing.

3.5.5.3

Ensure that the regulator and piping are clean and not contaminated.

3.5.5.4

Flow is proportional to input pressure which should not exceed 7 psi (0.483 bar, 48.3 kPa).

3.5.5.5

The analyser requires a supply of zero gas at all times when it is in operation.

3.5.6

**Sample**

3.5.6.1

Depending on the application, sample gas may be at an elevated temperature. Reduce the sample temperature to below 40 °C. Its dew point should be at least 10 °C below local ambient temperature.

3.5.6.2

Connect the sample line to the port labelled SAMPLE. Flow is proportional to input pressure.. Do not exceed 7 psi (0.483 bar, 48.3 kPa).

3.5.7

**Exhaust Outlet(s)**

3.5.7.1

If the sample contains toxic gases as defined by your local legislation, vent this outlet(s) to a safe area or in a manner described by the legislation.

3.5.7.2

Connect the rear panel port(s) labelled EXHAUST to a safe vent area using 1/4" thin walled tubing.

3.5.7.3

For dual range analysers with dual exhaust ports, separate exhaust lines should be used, and they should not be commoned less than 1 metre from the analyser.



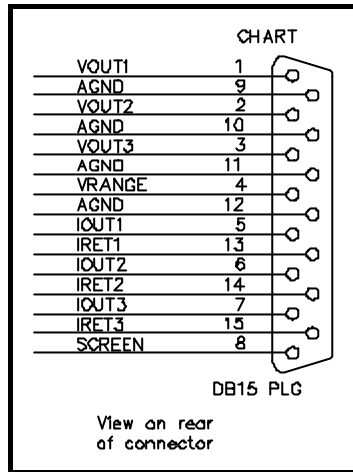

Figure 4 Chart Pin Allocations

Output	Function
VOUT1	Voltage Output
VOUT2	Not used
VOUT3	Not used
VRANGE	Range Voltage Output
IOOUT1	Current Output
IOOUT2	Not used
IOOUT3	Not used

Table 1 Chart Output Functions

### 3.6 Chart Connections

3.6.1 Identify the 15 way 'D' plug and housing in the accessory kit. It connects to the 15 way socket labelled CHART. Always use screened cable with the screen connected to the connector shell.

3.6.2 The connector pin allocations are shown in Figure 4. Not all pins are used.

3.6.3 VOUT2, VOUT3, IOOUT2, and IOOUT3 are not available in this analyser. The other functions are given in Table 1

3.6.4 A typical installation may use VOUT1 and VRANGE connected directly to an adjacent chart recorder, or IOOUT1 connected to a remote data logger. Voltage and current outputs are available at the same time and are non-interactive.

3.6.5 VRANGE can be used over long distances. Any voltage drop down

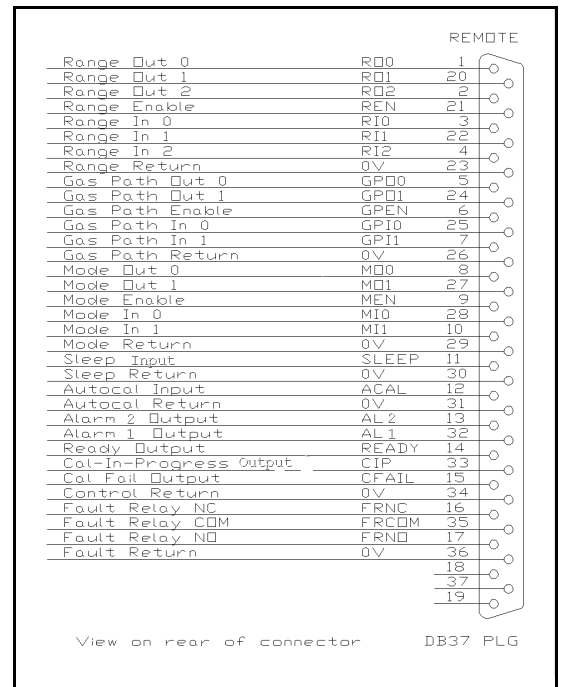

Figure 3 Remote Connections

Range N°	Output	
	Low Voltage	High Voltage
1	0.6	1.4
2	1.6	2.4
3	2.6	3.4
4	3.6	4.4
5	4.6	5.4
6	5.6	6.4

Table 2 Range Output Voltages

the line just offsets the trace slightly. Range indication does not require great accuracy. A good rule of thumb is to use integer voltages  $\pm 0.4$  Vdc to

indicate the range. A voltage below 0.6 Vdc indicates analyser off or loss of power. A list of recommended voltage limits is given in Table 2.

### 3.7 Remote Connections

- 3.7.1 Identify the 37 way 'D' plug and housing in the accessory kit. It connects to the 37 way socket labelled REMOTE on the rear panel. Always use screened cable with the screen connected to the connector shell.
- 3.7.2 The connector pin allocations are given in Figure 3. Not all functions are available in this analyser. Refer to section 7 for full information.
- 3.7.3 Typical connections for switch, logic, and isolated logic are given in Figure 5 on page 18. The grounded switch method of control is useful where the analyser must be placed in a different area from the control and where only manual control is required. Computer or process controllers should use the direct or isolated method of operation. Isolated connections should be used if the analyser is in an electrically noisy environment, with the analyser some distance from the controlling logic, and where the controlling logic is connected to the local earth.
- 3.7.4 Some remote logic drives have sufficient drive to supply power to the CPU card via the I/O lines when the analyser is switched off. This can cause an E2 Watchdog Reset code to be displayed on the self check status page after switching off with the remote logic left switched on. The code can be ignored under these conditions.

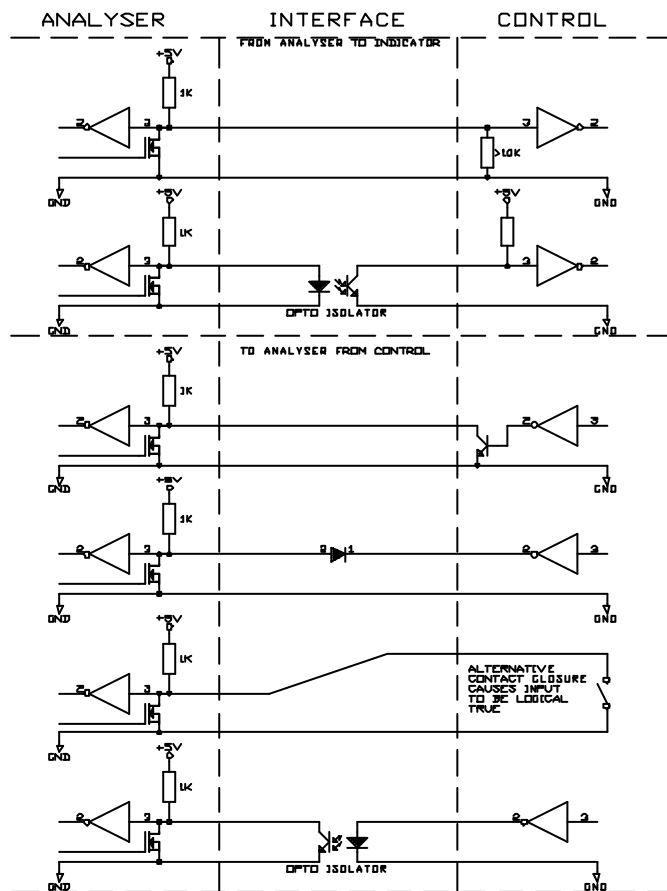

Figure 5 Typical Remote Logic Connections

- 3.7.5 This condition can be eliminated by using opto-isolated couplings, by ensuring that the remote control devices have open collector drives and inputs without pull-up resistors, or by inserting small signal Schottky diodes in series with all control lines (anodes to the analyser).
- 3.7.6 Volt free relay contacts are available to warn of a fault or error condition within the analyser. The FRCOM (common) contact will be connected to the FRNC (normally closed) contact when there is no power to the analyser and when there is a fault or error condition. The FRCOM contact will be connected to the FRNO (normally open) contact when power is present and there is no fault or error condition detected. A local 0V pin is available on the connector if it is necessary for the fault detection logic to share the same ground line as the other logic signals.

### 3.8 RS232 Connection

- 3.8.1 Identify the 9 way 'D' socket and housing in the accessory kit. It connects to the 9way plug labelled RS232 on the rear panel. Always use screened cable with the screen connected to the connector shell.
- 3.8.2 The connector pin allocations are given in Figure 6.
- 3.8.3 The factory default for RS232 configuration is 9600 baud, no parity, 8 data bits, 1 stop bit, and with XON/XOFF enabled.
- 3.8.4 The configuration can be changed from the front panel using one of the SET menus. Refer to section 6.5.9.

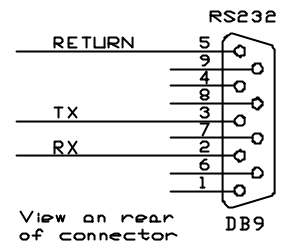

Figure 6  
RS232  
Connection

## 4. BASIC OPERATION

### 4.1 Introduction

- 4.1.1 The following instructions guide you through the basic steps necessary to make measurements. Full instructions for all measurement modes and programmable functions are given in the OPERATION section of the manual. The date and time displayed when switched on may not be correct. This does not affect the basic operation of the analyser. If you want to correct it, refer to section 6.5.5 for full instructions.
- 4.1.2 The contents of the screen, and the function of the row of keys just below the display change according to the operation being performed. Labels for the top row of keys are shown on the display. In the following instructions, these variable key functions are shown in { } brackets while the other (fixed) key functions are shown in [] brackets.
- 4.1.3 If the function in { } brackets is not displayed on the screen when you are required to press it, press [ESCAPE] and repeat the whole key sequence from the beginning.
- 4.1.4 Refer to the ANALYSER CONTROLS section of the manual for a full description of all key sequences.

### 4.2 Installation

**CAUTION :** the temperature of the sample must be kept to less than 40 °C, and the dew point to at least 10 °C below the local ambient temperature.

- 4.2.1 Connect the sample to the rear panel port labelled SAMPLE. The inlet pressure must be in the range -5 psig (0.35 bar, 35 kPa) to 7 psig (0.483 bar, 48.3 kPa) with respect to atmospheric pressure to keep the flow within working limits. The flow meter to the right of the display can be used as a guide; the 'float' should be within the two markers for normal operation. You will need the sample pump option for negative pressures.
- 4.2.2 You will require a source of span calibration gas. The actual concentration should be similar to the expected range of results.
- 4.2.2.1 Connect a span calibration gas supply to the rear panel port labelled SPAN. Set the pressure to 10 psig (0.689 bar, 68.9 kPa).
- 4.2.3 You will also require a source of zero calibration gas (Nitrogen).
- 4.2.3.1 Connect a zero calibration gas supply to the rear panel port labelled ZERO. Set the pressure to 10 psig (0.689 bar, 68.9 kPa).
- 4.2.3.2 The analyser requires a supply of zero gas at all times when it is in operation.
- 4.2.4 Connect the outlet port(s) labelled EXHAUST to a safe vent area using 1/4" thin walled or larger piping. For dual range analysers with dual exhausts, use separate exhaust lines, and do not common them less than 1 metre from the analyser.

### 4.3 Operation

- 4.3.1 Switch on using the front panel switch in the right bottom corner. Press '1' to turn on and '0' to turn off. The top edge of the switch will show a blue colour when on.
- 4.3.2 After power has been switched on and some initial start-up screens have been presented, the display will show the basic measurement, or PRIMARY screen. If you are using the analyser in low ambient light conditions, find and press the {ILLM} key on the bottom row of the screen to toggle the back-light on. If the ambient light is very bright, press the {ILLM} key to toggle the back-light off to improve the contrast.

- 4.3.3 The basic display shows the current condition of the analyser immediately under the concentration display.
- 4.3.4 The current range is also shown immediately under the concentration display. If the range is not followed by the word AUTO ... press the [RANGE] button. The screen will label two of the upper row of buttons to show {MANUAL} and {AUTO}. Press {AUTO} to set automatic range changing.
- 4.3.5 Notice that to the right of the concentration the units are ppm or % and that the gas to be measured is displayed.
- 4.3.6 Find the {SAMP} legend on the bottom row of the display and press the key immediately below it.
- 4.3.7 Once the displayed condition is **SAMPLE**, you are measuring the sample gas in ppm or % volume per volume concentration.
- 4.3.8 The analyser is configured at the factory for a calibration concentration value equal to the highest range. If your calibration gas has a different value you must re-configure before you calibrate otherwise the calibration will fail. In addition to the concentration value, you must choose a range to use during calibration. The concentration must be between 10 % and 115 % of the selected range.
- 4.3.9 To re-configure the analyser calibration ...
- 4.3.9.1 Press [SET]{SPAN} to display the current settings for calibration.
- 4.3.9.2 Use the [<], [>], [^], or [v] keys to select the span value. Press {EDIT} then the number keys (numbers are printed on the panel above the key) to enter the value. If you enter a wrong number use the {DEL} key to erase the last entry. When the number is correct press {EDIT} again.
- 4.3.9.3 Use the [<], [>], [^], or [v] keys to select the range. Press {EDIT} then the [^], or [v] keys to select the range to use during calibration. Press {EDIT} again.
- 4.3.9.4 If the screen now shows the required calibration value and range, press [SET] to accept the new data then [ESCAPE] to return to the primary screen.
- 4.3.10 Unless the analyser was recently calibrated, the concentration value may not be as accurate as you require. Press {CAL} and the analyser will automatically calibrate the zero and span. When it has finished calibrating it will return to measuring sample.
- 4.3.10.1 Press [STATUS][PAGE↓] to see the calibration results. If the calibration failed, check that both zero and span gas bottle valves are open and that the correct span calibration concentration value has been entered (check the calibration certificate that came with the cylinder).
- 4.3.11 If you accidentally press a key and the primary screen is replaced by a different one, press [ESCAPE] to restore the primary screen. [ESCAPE] will always return you to the primary screen from anywhere in the menu structure.

## 4.4 Shut-down

- 4.4.1 Press the key labelled by the display as **{STOP}**. The analyser will stop measuring and all internal functions not necessary for operation will be turned off. The full shutdown procedure will take several minutes while the sample line is being purged. The condition **STANDBY** will be displayed when the shutdown procedure is complete.
- 4.4.2 Close all valves on the fuel and calibration gas supplies. Disconnect all piping and cables.
- 4.4.3 Turn the analyser off.

## 5. OPERATION

### 5.1 Introduction

- 5.1.1 Analyser operation is controlled directly by the operator from the front panel, by logic control commands from a remote panel, or by RS232 serial port commands from a host computer or by a PC with custom software.
- 5.1.2 This section explains in detail how to operate the analyser using the front panel controls. It includes all configuration instructions, and interpretation of the status information. Refer to sections 7 and 8 for remote control instructions.

### 5.2 Analyser Basics

- 5.2.1 The detector output is proportional to the number of relevant molecules in the optical path. It is therefore proportional to the path length as well as the absolute pressure and temperature in the chamber. The chamber is vented to the exhaust port(s) and is therefore at the exhaust port(s) pressure. Venting the exhaust port to a safe vent area can lead to an increase in pressure seen at the port and will therefore affect the reading. This can be calibrated out if the pressure remains constant. A varying pressure will lead to calibration errors for slowly changing pressures, or to noise for fast changing pressures.
- 5.2.2 The front panel display and keys allow you to read the measured concentration, to configure the analyser for your particular requirements, or to interrogate it for operational status.
- 5.2.3 All gas inputs and exhausts are connected at the rear panel.
- 5.2.4 Power connections, chart recorder outputs and remote control connections are on the rear panel.
- 5.2.5 The analyser shows the current concentration on the front panel display, via chart recorder outputs, or via the RS232 serial port after an interrogation command.
- 5.2.6 Additional Reading
- 5.2.6.1 Refer to section 2 for full installation instructions.
- 5.2.6.2 Refer to section 4 for basic operating instructions.
- 5.2.6.3 Refer to section 6 for a full description of all key functions.

### 5.3 Manual Operation

- 5.3.1 The analyser is controlled using the keys on the front panel and information is read from the back-lit display.
- 5.3.2 The analyser's primary function is to display the concentration value. Gas path, range, sample flow, chart recorder output, and health check status are immediately available. Secondary viewing screens give more detailed status information.
- 5.3.3 The screen layout varies depending on the information it needs to show you. Three basic types of display show primary, status, and configuration information and are accessed using the [ESCAPE], [STATUS] and [SET] keys.
- 5.3.4 A menu structure is used to gain access to all features. The three basic types of display have more than one page of information and which are accessed using the [PAGE↑] and [PAGE↓] keys.

5.3.5 The top row of six keys change function according to the information the analyser expects from you. This simplifies key entry since only functions applicable to your input are available. These keys are called 'SOFT' keys.

5.3.6 All other keys have fixed functions and are called 'HARD' keys.

## 5.4 Primary Screen

5.4.1 The primary screen displays basic information and the most frequently used soft key functions. It can always be reached by pressing the [ESCAPE] key from anywhere in the menu structure. From this screen you can reach all other information and configuration screens.

### 5.4.2 Concentration

5.4.2.1 The concentration is displayed in large characters with the units and gas shown in smaller characters immediately to the right.

5.4.2.2 The value is displayed with up to four significant figures, a floating decimal point, and leading zero suppression.

### 5.4.3 Bar Graph

5.4.3.1 To the left of the display is a vertical bar graph showing the fraction of the chart output represented by the concentration for the current range.

### 5.4.4 Alarm Levels

5.4.4.1 To the right of the bar graph is a vertical line on which are placed any alarm points that occur on that range. A high alarm is indicated by a right angled triangle with the base at the top, and a low level alarm is indicated by a right angle triangle with the base at the bottom. Two alarm levels may overlap on the display. Refer to section 5.11 for instructions to view the numerical values and to section 6.5.2 to set them.

### 5.4.5 Flow

5.4.5.1 The gas flow from the selected input port (sample, span, or zero) is displayed as a 'float' at the right of the display. Keep the flow between the two markers for specified performance.

5.4.5.2 Flow is dependant on the pressure at the input ports. The sample port goes directly to a particulate filter and the flow is controlled by an internal restrictor referenced to the bypass pressure. The zero and span ports have additional input restrictors to allow use from gas bottles. Flow is controlled by adjusting the inlet pressures. Keep the 'float' within the two markers for specified performance.

### 5.4.6 Range

5.4.6.1 This refers mainly to the chart recorder output range and the fraction of the range displayed on the bar graph. The displayed digits are limited to the selected range. Internal electrical ranges are not the same as the displayed ranges and are set by the microprocessor to optimise resolution.

5.4.6.2 Range information is placed below the concentration and shows the range and units that are being used. The word AUTO is placed after the range information if automatic range changing has been selected.

### 5.4.7 Control

5.4.7.1 To the right of the display and on the same line as the range information is an indication of the control method for the analyser. Control types are LOCAL ONLY, SERIAL ONLY, LOGIC, and LOCAL.

- 5.4.7.1.1 LOCAL ONLY.
- 5.4.7.1.1.1 The analyser will not respond to a remote control command from any source.
- 5.4.7.1.2 SERIAL ONLY.
- 5.4.7.1.2.1 The analyser will only change range, gas path, and initiate calibration when the command is received from the serial port. These functions are removed from the soft keys.
- 5.4.7.1.2.2 No response to logic commands will be made even if logic control is enabled.
- 5.4.7.1.3 LOGIC.
- 5.4.7.1.3.1 The analyser can change range, gas path, initiate calibration, or place the analyser into standby from the logic inputs. These functions are removed from the soft keys. Front panel keys for functions under remote control are ignored.
- 5.4.7.1.3.2 If serial control is enabled and the serial port sends an SREM command, control will change to SERIAL ONLY.
- 5.4.7.1.4 LOCAL.
- 5.4.7.1.4.1 Serial or logic control has been enabled. The analyser will continue to respond to key controls provided that no request for serial control has been received at the serial port, and that logic control for that function has not been selected.
- 5.4.7.1.4.2 Serial port control is established when an SREM command is received, and relinquished when an SMAN command is received. The display will show SERIAL ONLY while in serial remote control. The serial port control will always prevent access via the keys or the logic inputs.
- 5.4.7.1.4.3 Logic control for a particular function will be enabled when the enable line for that function is set (short to ground, a logic 1, or a 0V logic level). Control from the front panel will be disabled for those functions under logic control.
- 5.4.8 Activity
- 5.4.8.1 This area is immediately below the range information and displays the current analyser activity. The most common activities are SAMPLE, STANDBY, CALIBRATING, ZERO, and SPAN. Other messages may appear in this area.
- 5.4.9 Messages
- 5.4.9.1 There is a message area underneath the Control information where the condition of the calibration and internal health check is displayed. A “Warning” allows you to continue with your measurements but you must treat the results with caution. A “Fail” has detected an invalid conditions and has set the analyser into a safe condition which prevents sample measurement.
- 5.4.9.2 ‘Status Fail’ or ‘Status Warning’ will be displayed if one of the health checks is outside limits. ‘Cal Warning’ will be displayed if the last calibration failed and there are no other health checks out of limit. Scroll through the status pages to find the problem.
- 5.4.9.3 ‘Status Fail’ stops sample measurement and puts the analyser into standby. Zero and Span can be selected while the source of the fault is located. ‘Status Warning’ allows normal analyser operation from all gas paths.
- 5.4.9.4 ‘Cal Warning’ means that the last calibration failed and that the previous calibration results are still being used. It will remain displayed until a full, valid, calibration is performed ({SAMPLE}{CAL}).



- 5.4.10 Soft Keys.
- 5.4.10.1 {SAMP} selects measurement of the sample inlet port.
- 5.4.10.2 {STOP} causes the analyser to enter a STANDBY mode after purging the internal gas path with zero gas, turning off the pump.
- 5.4.10.3 {ILLM} switches the display back-light on or off.
- 5.4.10.4 {CAL} causes the analyser to perform a calibration. The type of calibration depends on the gas path. Refer to section 5.9.

## 5.5 Key Protection

- 5.5.1 All configuration, gas path, and range changing keys can be disabled leaving the primary and status screens available for viewing.
- 5.5.2 If there is no response to a soft key, press [STATUS] and read the state of key protection at the bottom right of the screen. Keys should be ENABLED for front panel control. Press [ESCAPE].
- 5.5.3 If Keys are DISABLED you will need to enable them. Refer to section 6.5.6 for instructions.

## 5.6 Second Display Screen

- 5.6.1 Press the key labelled [PAGE↓]. An alternative set of soft key functions will be displayed. All other parts of the screen are identical to the primary screen.
- 5.6.2 Soft Keys
- 5.6.2.1 {SAMP} selects measurement of the sample inlet port and performs as the primary screen.
- 5.6.2.2 {SPAN} selects measurement from the span inlet port.
- 5.6.2.3 {ZERO} selects measurement from the zero inlet port.
- 5.6.2.4 {CAL} causes the analyser to perform a calibration. The type of calibration depends on the gas path. Refer to section 5.9.
- 5.6.3 To return to the Primary screen, press the key labelled [PAGE↑] or [ESCAPE].

## 5.7 Manual Range Selection

- 5.7.1 The current range is shown immediately under the concentration display. If the range is followed by the word AUTO it is in automatic range changing mode. Change to manual mode using the following sequence.
- 5.7.1.1 Press the [RANGE] key. The screen will label two of the upper row of buttons to show MANUAL and AUTO. Press {MANUAL}.
- 5.7.2 Press the [^] key to change to a higher range, or the [v] key to change to a lower range. The ranges 'wrap around' so that the next 'higher' range beyond the highest is the lowest, and the next 'lower' range than the lowest is the highest. This 'wrap around' does not occur with automatic range changing.

## 5.8 Automatic Range Selection

- 5.8.1 The current range is shown immediately under the concentration display. If the range information is not followed by the word AUTO, it is in manual range changing mode. Change to automatic mode using the following sequence.

- 5.8.2 Press the [RANGE] key. The screen will label two of the upper row of buttons to show MANUAL and AUTO. Press {AUTO}.
- 5.8.2.1 A change up will occur if the concentration goes above 95% of the current range, and a change down will occur if the concentration falls below 80% of the next lower range.
- 5.8.2.2 Range disabling can be used to prevent particular ranges being selected. Automatic range changing can only use enabled ranges. Refer to section 5.12.10 for full information.

## 5.9 Calibration

- 5.9.1 Calibration performs an internal adjustment of the zero point and span points.
- 5.9.2 You will require a source of span calibration gas. Calibration 'cocktails' containing a mixture of calibration gases for the simultaneous calibration of different gas analysers are allowable provided that the gases will not react with each other or with the analyser gas path materials. You should use a calibration value of the same order as the value you expect to be measuring. You will also require a source of zero calibration gas (Nitrogen). The span gas should use the zero gas as a diluent.

- 5.9.3 The type of calibration performed depends on the gas path selected. Refer to Table 3 for the combinations. Pressing {CAL} when sample is selected calibrates both zero and span, automatically selecting the Zero and Span ports as calibration proceeds.

Gas Path	Calibration
Zero	Zero Only
Span	Span Only
Sample	Zero and Span

- 5.9.3.1 Zero calibrates the zero points on each range.

- 5.9.3.2 Span calibrates the analyser gain.

- 5.9.4 Press the key labelled by the display as {CAL}. The analyser will automatically calibrate itself using the zero and/or span gases connected to the rear panel ports. During the calibration period, the display will show the word CALIBRATING in the activity area. After calibration, the analyser updates the internal offset and scaling factors using the results of the calibration. If the calibration failed, a 'Cal Warning' message is placed on the display to the right of the activity area..

**Table 3 Calibration Types**

- 5.9.5 Calibration uses the span concentration value entered using [SET]{SPAN}. The factory default is full scale on the highest range. Restoring factory defaults also clears any additional linearisation information that has been entered using the 'AK' commands.

- 5.9.5.1 A common cause of calibration failure is an incorrect value for the span gas, and normally occurs after a cylinder is changed. Always check the cylinder certificate, and, if possible, repeat the calibration with a different cylinder, when a calibration failure occurs.

- 5.9.5.2 Calibration failure also occurs when the dynamic range of the analogue to digital converter is exceeded. This normally results from a reduced sensitivity due to a dirty optical path. The analyser requires a full service if the detector fails and should be returned to Signal or one of our authorised agents.

- 5.9.6 A calibration that fails does not change the internal offset and scaling factors; it continues to use the original ones. This allows continued use of the analyser until the cause of the failure can be determined and a correction then applied to the acquired data. After you have all the data from your run, apply zero and span gas and record the results. Use the results to correct your data. Determine the reason for the calibration failure and re-calibrate the analyser.

- 5.9.7 A combined zero and span calibration performs the zero part first. If the zero calibration fails, a span calibration is not performed. If the zero calibration is successful but span

calibration fails, neither the internal offset nor the scaling factors are updated so that continuity with previous readings can be maintained.

- 5.9.8 A manual calibration can be aborted at any time by pressing the {ABORT} soft key. The internal offset and scaling factors are not updated. An automatic calibration (time of day or interval, refer to section 5.12.6) cannot be stopped.

## 5.10 Password Protection

- 5.10.1 To prevent inadvertent changes to the operational status of the analyser, any keys that affect gas path, range, and configuration can be disabled and password protected. Refer to section 6.5.6 for instructions. Make sure that you keep a record if you change from the default password to one of your own.

## 5.11 Interrogation Instructions

- 5.11.1 Press the key labelled [STATUS]. The display changes to a text screen containing basic information about the analyser status. Further screens are available using the [PAGE↓] key. Use the [PAGE↑] key to return to a previous status screen.
- 5.11.2 General Status
- 5.11.2.1 This page shows the general status of the analyser. The top line shows the analyser type, status type, and the current date and time. A second press on the [STATUS] key causes the date and time to be replaced by concentration. The display toggles between these two modes for each press on the [STATUS] key. This facility is available on all status pages.
- 5.11.2.2 **Activity** shows the current operation in progress. This can be STANDBY, PURGING... nnnS, or CALIBRATING. STANDBY is an operational condition that keeps the detector at its working temperature, but deactivates the gas path and the pump. PURGING is the intermediate stage before standby is achieved during which the sample path is purged with zero gas. A 'seconds' count-down to zero shows the progress through the purge sequence.
- 5.11.2.3 **Gas Path** shows the gas input port used for analysis. The ports are SAMPLE, SPAN, and ZERO. An additional indication of OFF is shown when all input ports are closed during standby.
- 5.11.2.4 **Flow** shows the approximate sample flow in l/min. Digitisation may cause the value to be negative or non-zero when no flow exists. This is not an error condition.
- 5.11.2.5 **Alarm 1 and Alarm 2** show the settings of the alarm levels. The value will be preceded by > for a high alarm (the alarm operates on concentrations greater than the value) or by < for a low alarm (the alarm operates on concentrations less than the value). Flashing text indicates that the alarm condition exists.
- 5.11.2.6 **Control** shows the technique that controls the analyser. It may be LOCAL ONLY, SERIAL ONLY, LOGIC, or LOCAL. The first two are self descriptive. LOGIC means that one or more functions are under the control of logic inputs. LOCAL means that it is currently under local control but either logic or serial control could occur disabling the local control. Refer to section 5.12.11 for a full explanation of remote control.
- 5.11.2.7 **Pump** shows the status as ON or OFF.
- 5.11.2.8 **Protection** shows the front panel keys as ENABLED or DISABLED. Key disabling is a feature available in one of the [SET] menus. When disabled, only the status and primary screens, plus the [SET]{KEY} configuration function are accessible from the front panel.
- 5.11.3 Calibration Status
- 5.11.3.1 This page shows the analyser calibration status. The top line shows the analyser type, status type, and the current date and time.

- 5.11.3.2 The next line shows the date and time of the last calibration.
- 5.11.3.3 If automatic calibration has been set, the next line show the date and time that the next calibration is due.
- 5.11.3.4 Calibration determines the mapping of the raw data to a range offset and scaling factor. The raw data range is that of the internal Analogue-to-Digital Converter. There is an allowed range of raw data for zero offset and scaling (span) variations. The actual location of the zero and span factors within their allowed bands is expressed as a percentage and displayed on the screen. If the zero or span locations fall outside the allowed bands (i.e. greater than 100% of band) the calibration will fail.
- 5.11.3.5 If a calibration fails, the calibration factors are not updated. If they had been, severe non-linearity would occur making the analyser unusable without routine maintenance. Leaving the original calibration factors unchanged allows the analyser to be used and correction factors applied to the results at a later date.
- 5.11.3.6 The display is arranged in three main columns and shows the location of the current calibration factors within their allowed range and the results of the last calibration for each calibration type. The first column shows the calibration TYPE (Zero, Span). The second column shows the CURRENT location of the calibration factors within their allowed bands. The third column show the RESULT of the last calibration. Calibration factors of 100% or more represent a failed calibration.

5.11.3.6.1 If the type of calibration was included in the last calibrate command a \* is placed to the right of the RESULT column. No \* means that the data is from an earlier calibration.

Left	Right	Meaning
		This type of calibration was not attempted and therefore no data transferred. The result shown is from an earlier calibration which failed, or from factory default values.
	*	This last calibration failed and the data was not transferred.
←		An earlier calibration was successful and the data was transferred for current use.
←	*	This last calibration was successful and the data was transferred for current use.

Table 4 Calibration Results

5.11.3.6.2 If the calibration was good, a ← is placed to the left of the RESULT column to show that the calibration factor was made current as a result of the calibration. No ← means that the calibration failed and the factor was not updated.

- 5.11.3.6.3 Table 4 shows the meaning given to the symbol combinations.
- 5.11.3.7 Use the figure in the Current column to determine how close to the limits the calibration factors are, and to make a judgement on the necessity for routine maintenance. We advise maintenance for calibration factors over 80% but be guided more by the rate of change than the absolute value.

5.11.4 Health Status

- 5.11.4.1 This page shows the analyser health status. The top line shows the analyser type, status type, and the current date and time.
- 5.11.4.2 **Amb Temp** give the current ambient temperature in the vicinity of the internal electronic module. It will be about 15 °C higher than the surrounding ambient. Internal ambient temperatures greater than 58 °C will cause a health check failure and put the analyser into standby.
- 5.11.4.3 **P.S. Status** shows the low voltage power supply health check as GOOD or FAULT. Power supply problems will cause a health check failure and put the analyser into standby.

- 5.11.4.3.1 A failure of the +5V rail to lower than about 4.5 Vdc prevents the display and CPU from working and cannot be indicated. Total operational failure or repeated showing of the initial start-up screen and the audible ‘beep’ are symptomatic of this failure mode.
- 5.11.4.4 **Ref Press** gives the internal purge pressure in mbar. A status warning will be given if the pressure goes outside the limits of 50 mbar and 3500 mbar.
- 5.11.4.5 **Flow** shows the selected gas port flow in l/min. The figure is only an approximation. Flows less than 0.2 l/min or greater than 2.0 l/min will cause a health check warning.
- 5.11.5 Self Check Status
- 5.11.5.1 This page shows the self check status. The top line shows the analyser type, status type, and the current date and time.
- 5.11.5.2 The display is arranged in columns showing the **Fault Code** and its **Description** for the six highest priority faults. If there are more than six fault conditions, the lowest priority ones are not displayed. A full list of the fault codes is given in section 9.
- 5.11.5.3 The self check status page of a working and measuring analyser shows no errors.
- 5.11.5.4 To maintain compatibility with the ‘AK’ protocol and its error reporting structure, the Health Status indications are reported as error conditions if outside acceptable limits. These will be shown on this page.
- 5.11.6 Alternative Status Display
- 5.11.6.1 While viewing any status page, a further press of the [STATUS] key changes the date and time display area to show measured concentration. The [STATUS] key toggles between the two modes for each [STATUS] key press.

## 5.12 Configuration

- 5.12.1 The analyser can be configured using the [SET] key. Pressing [SET] will cause the top row of keys to be redefined. These show the particular parameters that can be configured. A press on [PAGE↓] will give a further selection. Pressing one of these ‘soft’ keys changes the screen to show the current configuration for that function and allows it to be changed. A full description of all configuration instructions is given in section 6.5 including all key sequences required to complete each parameter.
- 5.12.2 The basic sequence for all parameter setting is to press [SET], then the parameter to be changed, then select a particular section using the arrow keys, press {EDIT} to edit it using the arrow or digit keys, press {EDIT} to accept the setting, then [SET] to confirm all data, then [ESCAPE] to restore the primary screen.
- 5.12.2.1 [SET]{parameter}(<, >, v, ^){EDIT}(&, v, or digits){EDIT}[SET][ESCAPE].
- 5.12.3 All configuration parameters are set to default values when the analyser is shipped. These values can be restored for any parameter by pressing [SET]{parameter}{RESET}[SET][ESCAPE].
- 5.12.4 While in the SET mode, and during any editing stage prior to the final [SET], pressing {CLR} restores the original values before any editing took place.
- 5.12.5 {ALARMS}
- 5.12.5.1 There are two alarms that can each be set to operate. When a condition is true, the AL1 or AL2 outputs on the remote control connector go low.
- 5.12.5.2 Each alarm can be set for high or low warning; you can have both as high alarms, both as low alarms, or one of each.

- 5.12.5.3 The alarm value can be set anywhere within the measuring range of the analyser. The analyser must be on a suitable range for the alarm to take effect. An alarm set to operate if the level exceeds 8 % will not function if the range is set to 5 %. Where widely varying concentrations are expected, and when both caution and warning alarms are required on different ranges, it is best to set the analyser range to AUTO.
- 5.12.5.4 Each alarm can be turned on or off without re-programming the level.
- 5.12.5.5 To be compatible with the model 102 Signal Host computer, Alarm 1 must be set to a high alarm and Alarm 2 to a low alarm. The host computer makes this assumption when analysing the input data.
- 5.12.6 {CAL}
- 5.12.6.1 Calibration can be made to occur automatically after an interval or at a particular time of day. These calibrations will be in addition to any manually requested calibration.
- 5.12.6.2 If the analyser has been switched off, there may be a calibration pending. This will occur automatically as soon as the analyser is ready for use. This is most effective when the pump control adaptor is fitted and the analyser can automatically control remote pumps.
- 5.12.6.3 Enable or disable the INTERVAL or DAILY type of automatic calibration.
- 5.12.6.3.1 For interval calibration select the period between calibrations.
- 5.12.6.3.2 For time of day calibration select the time of day that you want the calibration to be performed using 24 hour format (hh:mm).
- 5.12.6.3.3 Select which parameters are to be calibrated, ZERO and/or SPAN.
- 5.12.7 {CHART}
- 5.12.7.1 This is a quality audit utility that allows the chart output(s) to be set to four defined levels irrespective of the concentration value. This is useful for confirming that the full range of signals can be received by your chart recorder. Both voltage and current outputs are affected. The Range output is not affected.
- 5.12.7.2 {CHART} is on the second page of the [SET] screen. You must press [ESCAPE] to exit.
- 5.12.8 {CLOCK}
- 5.12.8.1 The internal clock provides date and time information for automatic calibration. It should be set to your local time using 24 hour format (hh:mm).
- 5.12.8.2 The analyser will have been configured for the local UK date and time before shipment.
- 5.12.8.3 The factory default date and time of 00:00 01/01/1970 will be set if {RESET} is pressed. This is an arbitrary default that has no significance other than it is a common and convenient starting point for our service or test departments to use, and is compatible with many PC date and time utilities.
- 5.12.9 {KEY}
- 5.12.9.1 The front panel controls, except for the status pages and SET KEY function, can be disabled to prevent inadvertent changes to the operation or configuration. Password protection ensures minimum tampering.
- 5.12.9.2 {KEY} is on the second page of the [SET] screen.
- 5.12.10 {RANGE}
- 5.12.10.1 Ranges can be inhibited to prevent their inadvertent selection. They are skipped during automatic or manual range changing and the next allowed range is selected.
- 5.12.10.2 {RANGE} is on the second page of the [SET] screen.
- 5.12.10.3 Enable or inhibit ranges according to your requirement. At least one range must be enabled; a screen with all ranges inhibited will not be accepted.

- 5.12.11 {REM}
- 5.12.11.1 Remote control of the analyser can be achieved using the RS232 serial port and a host computer, or using logic input lines connected to switches or a computer. The primary screen shows the current method of analyser control. Inhibit or enable serial and logic control according to your requirements. It is preferable to enable only one.
- 5.12.11.2 Logic control via the remote connector allows selection of range, gas path, analyser calibration, and standby. It can indicate the range, gas path, alarm 1 and alarm 2 status, calibration in progress, the result of the last calibration, and analyser readiness. Range and gas path, are controlled by logic 'enable' lines. When these lines are taken low, the front panel controls are inhibited. The remote indication outputs are available at all times and for all modes of control.
- 5.12.11.3 The serial port control is more versatile than logic control and allows setting some of the configuration parameters. To prevent conflict, most front panel [SET] functions are inhibited during serial port remote control.
- 5.12.11.4 Full details of the logic and serial port controls are given in sections 7 and 8.
- 5.12.12 {RS232}
- 5.12.12.1 The RS232 ports are factory configured for 9600 Baud, 8 Data Bits, No Parity, 1 Stop Bit, and XON/XOFF enabled.
- 5.12.12.2 {RS232} is on the second page of the [SET] screen.
- 5.12.12.3 You can change the configuration to suit your requirements. The factory default is suitable for the 102 Host Computer normally provided with Signal Systems.
- 5.12.13 {SPAN}
- 5.12.13.1 Calibration gas is a known concentration of CO or CO<sub>2</sub> in a Nitrogen or Zero Grade Air diluent. Refer to section 5.9.2 to determine your requirements. Always use the same diluent as your ZERO calibration gas. Calibration 'cocktails' containing a mixture of calibration gases for the simultaneous calibration of different gas analysers are allowable provided that the gases will not react with each other.
- 5.12.13.2 Your calibration gas should have a concentration close to the range of values that you expect to be reading. Calibration is always performed on a selected range. The calibration gas concentration must be above 10% of the range and below 115% of the range.
- 5.12.13.3 Calibration relies on knowledge of the calibration cylinder gas concentration. A failure to calibrate is frequently associated with a change in calibration gas cylinder without updating the span value.
- 5.12.13.4 Enter the concentration from the bottle calibration certificate and the range on which to calibrate. Concentrations above 115 % or below 10 % of range will not be accepted.
- 5.12.13.5 Restoring factory defaults for the span concentration also restores the original linearisation tables. If you have linearised the analyser using the 'AK' commands, you will need to re-transmit the data or re-linearise the analyser.
- 5.12.14 {T/C}
- 5.12.14.1 Each range has an electronic time constant associated with it. This provides signal filtering to control the response to transient concentrations. You can change these time constants to suit your application. The smaller the time constant the faster the response. The larger the time constant the slower the response. It takes about three times the electrical time constant to go from 5 % to 95 % of a step change.
- 5.12.14.2 The physical response time cannot be made shorter than the pneumatic response of the analyser plus the input sample path delay.
- 5.12.14.3 The time constants are not operational during calibration.

- 5.12.14.4 Be cautious of setting long time constants when you frequently need to change range. Use the factory default times while setting up and re-programme them after you have started your measurements.
- 5.12.14.5 Select the range and set a time constant from 0.1 s up to 600 s in units of 0.1 s. You only need to set the time constants for the ranges that you are using.
- 5.12.14.6 Acceptance testing of the analyser must be performed with the time constants set to the values the analyser was shipped with (2.0 seconds).

## 5.13 LCD Optimisation

- 5.13.1 The front panel Liquid Crystal Display (LCD) has a wide but finite viewing angle. The contrast has been optimised for rack or bench operation where the viewer's eye is at or near the display level. It can be optimised for other viewing angles.

- 5.13.2 Open the front panel and locate the LCD contrast control at the bottom of the front edge of the CPU card. Adjust the control to give the best contrast when viewed from the required angle. Close and secure the front panel.

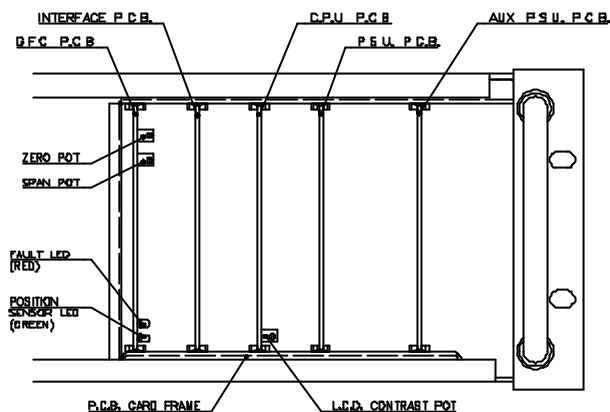

Figure 7 LCD Contrast Control

- 5.13.3 The contrast control is temperature compensated to match that of the LCD. During adjustment, the open panel may cause local temperature changes. Do not allow the front panel to remain open for long periods while optimising the LCD contrast.

## 5.14 Fault Relay

- 5.14.1 A fault relay is de-energised when an error condition exists that prevents the analyser operating correctly. Its contacts are available on the rear panel REMOTE connector. Refer to section 3.7 for installation instructions.
- 5.14.2 The most common error condition occurs when there is no power to the analyser. This could be due to a local power failure, mains lead not connected, analyser not switched on, fuse in mains plug faulty, or analyser fuse(s) faulty.
- 5.14.3 The microprocessor constantly monitors many operational parameters and will display an error code and message on the self check status page, and will output them on the serial port in response to an 'AK' ASTF command. Any error will cause the fault relay to de-energise. A list of codes is given in section 9.



## 5.15 Converting to Other Units

5.15.1 The analyser is calibrated in volume-per-volume units and expressed as parts per million (ppm) or percent (%).

5.15.2 Table 5 shows the relationship between ppm, %, and  $\text{g.m}^{-3}$  STP (Standard Temperature & Pressure, 101.3 kPa and 0 °C) and  $\text{g.m}^{-3}$  ISA (International Standard Atmosphere, 101.3 kPa and 15 °C). The numbers relate to the CO or CO<sub>2</sub> content of the sample. To convert from one unit to another locate the row where the known unit has a value of 1 and use the value in the other unit column as a multiplier.

Carbon Monoxide (CO)			
ppm	%	$\text{g.m}^{-3}$ (STP)	$\text{g.m}^{-3}$ (ISA)
1	0.0001000	0.001250	0.001185
10000	1	12.50	11.85
800.2	0.08002	1	0.948
844.1	0.08441	1.055	1
Carbon Dioxide (CO <sub>2</sub> )			
ppm	%	$\text{g.m}^{-3}$ (STP)	$\text{g.m}^{-3}$ (ISA)
1	0.0001000	0.001963	0.001861
10000	1	19.63	18.61
509.3	0.05093	1	0.948
537.3	0.05373	1.055	1

**Table 5 Converting to Other Units**

5.15.3 If you are using a chart recorder or data logger with an input scaling facility, it can be scaled to record directly in the required units.

## 6. ANALYSER CONTROLS

### 6.1 Front Panel Controls

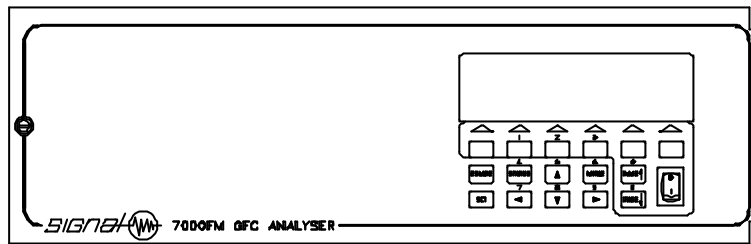

6.1.1

Figure 8 Front Panel Controls

### 6.2 Introduction

#### 6.2.1 Philosophy

- 6.2.1.1 The basic philosophy of analyser control is to give the user immediate access to the basic functions of measuring, not measuring (STANDBY), range, and calibration.
- 6.2.1.2 Installation and other performance checking functions are made available by pressing a single key [PAGE↓]. These functions include the selection of span and zero gas paths and the ability to calibrate span or zero individually.
- 6.2.1.3 The analyser status is available by pressing a single key. The screen changes to show the main analyser parameters, and supplementary screens with further parameters are obtained by pressing [PAGE↓].
- 6.2.1.4 Functions that allow the user to set particular operational parameters that would in themselves require many key presses are placed in menus to guide the user to the right set up screen.
- 6.2.1.5 In the event of a user losing track of the position in the menu structure, a single key press [ESCAPE] returns to the basic (or primary) screen.
- 6.2.1.6 This simple structure means that almost all functions can be obtained with a maximum of three key presses and only a single key press is necessary to escape back to the primary screen.

#### 6.2.2 Display

- 6.2.2.1 The display is a 240 x 64 matrix of dots which can display characters and graphics. Different displays are presented according to the function that the analyser is performing at the time.

#### 6.2.3 Key Types

- 6.2.3.1 There are two type of key on the keypad. The bottom two rows are called HARD keys because their functions are fixed (except for a few special cases). The top row of keys are called SOFT keys because their functions change under software control in response to the last key pressed. The function that the SOFT key will perform when pressed is indicated by the text on the screen immediately above the key. Throughout the manual references to soft keys are shown in { } brackets and hard keys in [ ] brackets.
- 6.2.3.2 Control is achieved by pressing a key to perform a desired function. A menu structure has been incorporated to ensure that the most often used functions are easily available while other functions, particularly those that set operating parameters, require more key presses to access them.
- 6.2.3.3 This structure allows many functions to be included that would otherwise require a large number of dedicated keys, while, at the same time, it allows immediate access to the few functions necessary for routine control.

- 6.2.3.4 To simplify numerical entry for many parameters, a central group of eleven keys are given the alternative actions of entering specific numbers. These alternative actions are only operative within a defined part of the SET procedure.

## 6.3 Hard Keys

- 6.3.1 [RANGE]
- 6.3.1.1 This key allows the selection of manual or automatic range changing. Manual range changing requires the operator to choose a single range using the [^] and [v] keys. When automatic changing has been selected, the [^] and [v] keys are inactive.
- 6.3.1.2 After pressing [RANGE] the soft keys change to show options MANUAL and AUTO. Press the {AUTO} key to select automatic range changing; press {MANUAL} to set manual range changing.
- 6.3.2 [^], [v], [<], and [>]
- 6.3.2.1 These keys are used for various functions depending upon the context.
- 6.3.2.2 From the primary screen they select the next higher or lower range. The ranges wrap around so that the next higher than the highest range is the lowest, and the next lower than the lowest range is the highest. Ranges that have been inhibited via the SET command are skipped.
- 6.3.2.3 From the SET screens they are used to select the parameter to edit and to change state. They also serve as number entry keys when a numerical value is required.
- 6.3.3 [STATUS]
- 6.3.3.1 This key selects the first of the status screens which show the important parameter settings and values. Use the PAGE↑ and PAGE↓ keys to view additional status screens.
- 6.3.4 [PAGE↑] and [PAGE↓]
- 6.3.4.1 These keys select any alternative screens or soft key selections that may be available under a particular function. Full information on the operation of these keys is given with each function that uses them.
- 6.3.5 [ESCAPE]
- 6.3.5.1 This key gets you back to the primary measurement screen from anywhere in the menu structure. Any partially completed SET functions are abandoned without executing any entered changes.
- 6.3.6 [SET]
- 6.3.6.1 This key calls the menus that allow access to all the user settable parameters that configure the analyser to suit the application. It also acts as the final confirmation of entered data.

## 6.4 Primary Soft Keys

- 6.4.1 {SAMP}
- 6.4.1.1 This key sets the analyser to measure the sample input. If the sample pump option is fitted, the pump will run in this mode.
- 6.4.2 {STOP}
- 6.4.2.1 This key sets the analyser into a standby condition with the pump not running and the gas paths shut off.
- 6.4.2.2 To ensure that the analyser is left in a clean state, a defined sequence is followed as the analyser enters the standby condition.

- 6.4.2.2.1 Zero gas is selected.
- 6.4.2.2.2 The sample path is purged with zero gas for a period of two minutes.
- 6.4.2.2.3 All gas paths are closed and the pump is turned off. This is the standby condition.
- 6.4.3 {ILLM}
- 6.4.3.1 This key controls the display back-light. The display gives good contrast under normal and high light conditions without the back-light. In low light conditions the display becomes more difficult to read and requires the back-light to be on. The back-light has a finite life and should be turned off when not required.
- 6.4.3.2 Pressing the {ILLM} key changes the back-light state from OFF to ON, or from ON to OFF.
- 6.4.4 {CAL}
- 6.4.4.1 Performs a full or partial calibration dependant on the gas path. Refer to Table 6.
- 6.4.5 {SPAN}
- 6.4.5.1 This key is available after pressing [PAGE↓] from the primary screen. It sets the analyser to measure the gas connected to the span port. This feature is useful during analyser installation or test preparation. Return to the primary screen by pressing [PAGE↑].

Gas Path	Calibration
Zero	Zero Only
Span	Span Only
Sample	Zero and Span

**Table 6 Calibration Types**

- 6.4.6 {ZERO}
- 6.4.6.1 This key is available after pressing [PAGE↓] from the primary screen. It sets the analyser to measure the gas connected to the zero port. This feature is useful during analyser installation or test preparation. Return to the primary screen by pressing [PAGE↑].
- ## 6.5 Set Functions
- 6.5.1 Basics
- 6.5.1.1 All SET operations are activated by pressing the [SET] key. Any SET sequence can be aborted by pressing the [ESCAPE] key at any time prior to the final [SET] that confirms the new setting.
- 6.5.1.2 When [SET] is pressed, a selection of functions that require setting is displayed above the soft keys. Choose one. If the one you want is not shown, use the [PAGE↑] or [PAGE↓] keys to display more alternatives.
- 6.5.1.3 Once the selection has been made the screen will change to show the current settings for that function. The soft keys will now show {RESET} (to restore factory defaults), {CLEAR} (to restore a changed value) and {EDIT}. Other soft keys may be present depending on the selection.
- 6.5.1.4 If more than one parameter is displayed, use the [^], [v], [<], and [>] keys to select the particular parameter to be changed. The selected text will appear in inverse mode (white on black).
- 6.5.1.5 When the required parameter has been selected press {EDIT}. This allows changes to be entered. The parameter field being edited will change to a flashing, inverse mode.
- 6.5.1.5.1 If the parameter has a numerical value, enter the value using the number keys. The value will go blank as the first key is pressed and the new value will be displayed as you press the keys.
- 6.5.1.5.2 If the parameter has a non-numerical value, for example range, use the [^] and [v] keys to move between the alternative states.

- 6.5.1.6 Press {EDIT} again to acknowledge the new value or state.
- 6.5.1.7 Use the [^], [v], [<], and [>] keys to select the next parameter to change.
- 6.5.1.8 If a mistake has been made, press {CLEAR} to restore all the parameters on the page to their original values or states when the screen was first invoked.
- 6.5.1.9 To restore all parameters on the screen to their factory default state press {RESET}.
- 6.5.1.10 Pressing [ESCAPE] at any time prior to the final acceptance will abort the set procedure without making any changes and will return to the primary screen with its soft keys.
- 6.5.1.11 When all editing on the page has been completed press [SET] to confirm the editing. The screen will change to the first SET screen to allow you to select the next function to change. Press [ESCAPE] to return to the primary display screen.
- 6.5.1.11.1 If a value is not within the allowed range of the parameter, an error message will be displayed and the value will not be accepted. Edit the field until the value is acceptable.
- 6.5.1.11.2 Alternatively, use the {CLEAR} key to restore the page to its original state, use the {RESET} key to restore the factory default values, or use the [ESCAPE] keys to exit the SET mode and cancel the change.
- 6.5.2 {ALARMS}
- 6.5.2.1 Alarms may be set anywhere within the working range of the analyser. The alarm will only operate if the current range can display that value. Unless you are using the auto-range facility, ensure that you select a measurement range that includes the highest alarm concentration.
- 6.5.2.2 Up to two alarms may be set.
- 6.5.2.3 Press [SET] {ALARM} [PAGE↑] or [PAGE↓] to select one of the SET ALARM screens.
- 6.5.2.4 Press [^], [v], [<], or [>] to select one alarm state (on or off). Press {EDIT}. Press [^] or [v] until the required state is obtained. Press {EDIT} to confirm.
- 6.5.2.5 Press [^], [v], [<], or [>] to select one alarm concentration. Press {EDIT}. Press the number keys to enter the value. Press {EDIT} to confirm.
- 6.5.2.6 Press [^], [v], [<], or [>] to select the units for one alarm. Press {EDIT}. Press [^] or [v] until the required units are displayed. Press {EDIT} to confirm.
- 6.5.2.7 Press [^], [v], [<], or [>] to select one alarm direction (high or low). Press {EDIT}. Press [^] or [v] until the required direction is obtained. Press {EDIT} to confirm.
- 6.5.2.8 Repeat for the other alarm if required.
- 6.5.2.9 Press [SET] to accept the new values and states. The display will show the first SET screen.
- 6.5.2.9.1 If an alarm value is outside the range of the analyser, an error message will be displayed. Use the [^], [v], [<], or [>] keys to select either the range or the value, press {EDIT} and re-enter the data. Press {EDIT} to confirm. Press [SET]. If the data is now valid, the display will change to the first SET screen otherwise an error message will be displayed again.
- 6.5.2.10 To recover original settings before pressing [SET] to accept the values :
- 6.5.2.10.1 Press {CLEAR} to restore the parameters to their original values or states when the screen was first invoked.
- 6.5.2.10.2 Press {RESET} to restore all parameters on the screen to their factory default states. The factory default is for AL1 to be set to 0 % LOW, and for AL2 to be set to 28.75 % HIGH. Both alarms are set OFF.
- 6.5.2.11 At any time during the SET ALARM mode, press [ESCAPE] to abandon the task and return to the primary screen with its soft keys without executing any changes.

- 6.5.3 {CAL}
- 6.5.3.1 Calibration can be performed manually, automatically at regular intervals, or automatically at certain times of the day. Span and Zero can be individually set.
- 6.5.3.2 Press [SET]{CAL} to select the SET CALIBRATION screen.
- 6.5.3.3 Press [^], [v], [<], or [>] to select the automatic calibration type. Press {EDIT}. Press [^] or [v] to enable or disable that type of calibration. Only one type can be enabled. Press {EDIT} to confirm.
- 6.5.3.4 Press [^], [v], [<], or [>] to select the interval or time of day value. Press {EDIT}. Use the number keys to set the interval or time of day. Press {EDIT} to confirm.
- 6.5.3.4.1 Intervals are in units of hours up to 750 hours and are entered directly.
- 6.5.3.4.2 Time of day uses hours and minutes and these are entered in 24 hour format. All four numbers including any zeroes must be entered.
- 6.5.3.5 Press [^], [v], [<], or [>] to select each calibrated parameter (ZERO or SPAN) and set it ON or OFF according to your requirements. Press {EDIT}. Press [^] or [v] for ON or OFF. Press {EDIT} to confirm.
- 6.5.3.6 Press [^], [v], [<], or [>] to select automatic calibration enable. Press {EDIT}. Press [^] or [v] to choose ON or OFF. Press {EDIT} to confirm.
- 6.5.3.7 To recover original settings :
- 6.5.3.7.1 Press {CLEAR} to restore the parameters to their original values or states when the screen was first invoked.
- 6.5.3.7.2 Press {RESET} to restore all parameters on the screen to their factory default states. The factory defaults are for all parameters to be calibrated once per day at 08:00, but not enabled.
- 6.5.3.8 Press [SET] to accept the new data. The display will show the first SET screen.
- 6.5.3.9 Press [ESCAPE] to return to the primary screen with its soft keys.
- 6.5.4 {CHART}
- 6.5.4.1 During system checks and quality audits it is frequently necessary to verify the chart recorder or analogue data acquisition levels. This CHART facility provides the necessary functions. Each chart output can be set to one of four check levels corresponding to -15%, 0%, 100%, and 115% of the range outputs, plus the concentration level.
- 6.5.4.2 Press [SET][PAGE↓]{CHART} to select the SET CHART screen. The soft keys will show {CONC} {-15%} {0%} {100%} {115%}. Press a key to make the chart outputs go to that level.
- 6.5.4.3 Press [ESCAPE] to return to normal operation.
- 6.5.4.4 A quality audit of the range output can be performed by pressing [ESCAPE] to go to the primary screen and then selecting each range in turn using the [^] and [v] keys.
- 6.5.5 {CLOCK}
- 6.5.5.1 A battery backed real time clock is used to control timed events. It should be set to local time and checked at monthly intervals when time-of-day functions are required. The clock is normally set to London local time for its default state when the analyser leaves the factory.
- 6.5.5.2 Press [SET]{CLOCK} to select the SET CLOCK screen. Two additional soft keys will appear; [LEFT] to move the cursor one digit left, [RIGHT] to move the cursor one digit right.

- 6.5.5.3 Press {EDIT}. Press the number keys to enter the year, month, date, hours, and minutes. Use the [LEFT] and [RIGHT] keys to go back or to skip as necessary. Press {EDIT} to confirm.
- 6.5.5.4 To recover original settings :
- 6.5.5.4.1 Press {CLEAR} to restore the parameters to their original values when the screen was first invoked.
- 6.5.5.4.2 Press {RESET} to set the date and time to the default state of 00:00:00 on 01/01/1970.
- 6.5.5.5 Press [SET] to accept the new data. The clock will be stopped, the new date and time applied, and the clock restarted. The display will show the first SET screen.
- 6.5.5.5.1 If the date is not valid (e.g. 30th February) an error message will be displayed and the cursor will remain on the screen. Correct the error and press [SET].
- 6.5.5.6 Press [ESCAPE] to return to the primary screen and its soft keys.
- 6.5.5.7 Setting the clock can interfere with the automatic calibrate times. **If you have any automatic calibrations set, you must re-confirm them by pressing [SET]{CAL}[SET].**
- 6.5.6 {KEY}
- 6.5.6.1 This function is provided to protect the analyser from inadvertent changes to its mode of operation. The range, gas path, manual calibration, and all the SET functions (except SET KEY) can be inhibited until a password is entered.
- 6.5.6.2 When protection is enabled, all soft keys that are no longer available will be removed from their screens.
- 6.5.6.3 To change protection :
- 6.5.6.3.1 Press [SET][PAGE↓]{KEY} to select the SET KEY screen.
- 6.5.6.3.2 The screen displays the messages "Password". Press {EDIT} and enter the password. Press {EDIT} again to complete the entry. The factory default is the analyser serial number. If an invalid password is entered, the display changes to the first set screen. Press [PAGE↓]{KEY} again to make another attempt or press [ESCAPE] to abandon the attempt.
- 6.5.6.3.3 If a valid password was entered the screen changes to show the current state of protection (ON or OFF) and the current password.
- 6.5.6.3.4 Press [^] or [v] to select the protection field. Press [^] or [v] to change the state.
- 6.5.6.3.5 Press [^] or [v] to select the password field. If you want to change the password press {EDIT} and use the number keys to enter a new password. Press {EDIT} to complete the entry. These will be the numbers that you must enter next time you need to change the protection state. The number can be any number from 0 to 99999. You only need to enter as many digits as you would like, up to the maximum of five. Be sure to make a note of your new password. There is an escape route if you forget it. Refer to section 11.3.
- 6.5.6.3.6 To recover original settings :
- 6.5.6.3.6.1 Press {CLEAR} to restore the parameters to their original values when the screen was first invoked.
- 6.5.6.3.6.2 Press {RESET} to set the factory default of protection OFF and with the serial number as the password.

- 6.5.6.4 Press [SET] to accept the new data. Key protection will be set or cleared and you will need to use the new password to access the key protection screen again. Press [ESCAPE] to return to the primary screen.
- 6.5.7 {RANGE}
- 6.5.7.1 Inhibits ranges you do not require to prevent their inadvertent selection.
- 6.5.7.2 When auto-range is selected, the change up will occur when the value goes above 95 % of the present range, and the change down will occur when the value goes below 80 % of the lower range.
- 6.5.7.2.1 Samples with a widely varying concentration around the change-over points may cause frequent switching. If this causes problems, select manual operation or enable an intermediate range.
- 6.5.7.2.2 The calibration procedure requires a particular range to be available. Range inhibit will not prevent the analyser automatically selecting this range during manual or automatic calibration.
- 6.5.7.3 Press [SET]{RANGE} to select the RANGE INHIBIT screen. The screen shows the available ranges and their status (ON or OFF).
- 6.5.7.4 Press [^], [v], [<], or [>] to select a particular range. Press {EDIT}. Press [^] or [v] to choose ON or OFF. Press {EDIT} to confirm. At least one range must be enabled.
- 6.5.7.5 To recover original settings :
- 6.5.7.5.1 Press {CLEAR} to restore the parameters to their original values or states when the screen was first invoked.
- 6.5.7.5.2 Press {RESET} to restore all parameters on the screen to their factory default states. The factory default is for all ranges to be enabled.
- 6.5.7.6 Press [SET] to accept the new data. The display will show the first SET screen.
- 6.5.7.7 Press [ESCAPE] to return to the primary screen.
- 6.5.8 {REM}
- 6.5.8.1 Selects the control mode of the analyser. Remote control of the analyser can be obtained using the serial port or the logic inputs. As supplied from the factory, only local control is enabled.
- 6.5.8.2 Press [SET]{REM} to display the SET REMOTE screen. The display will show a column for the type of control and a column for its status.
- 6.5.8.3 Press [<] or [>] to select the type of control.
- 6.5.8.4 Press {EDIT}. Press [^] or [v] to enable or inhibit that mode of control. Press {EDIT} to confirm entry.
- 6.5.8.5 To recover original settings :
- 6.5.8.5.1 Press {CLEAR} to restore the parameters to their original values or states when the screen was first invoked.
- 6.5.8.5.2 Press {RESET} to restore all parameters on the screen to their factory default states. The factory default mode is LOCAL ONLY.
- 6.5.8.6 To accept the code press [SET]. The display will show the first SET screen.
- 6.5.8.7 Press [ESCAPE] to return to the primary screen.
- 6.5.9 {RS232}
- 6.5.9.1 The RS232 ports can be configured for baud rate, parity, number of data and stop bits, and XON/XOFF control.
- 6.5.9.2 Press [SET][PAGE↓]{RS232} to select the SET RS232 screen.



- 6.5.9.3 Press [^], [v], [<], or [>] to select Baud, Parity, Stop, Data, or XON/XOFF. Press {EDIT} and use the [^], or [>] keys to select a value or state. Press {EDIT} to confirm.
- 6.5.9.4 To recover original settings :
- 6.5.9.4.1 Press {CLEAR} to restore the parameters to their original values or states when the screen was first invoked.
- 6.5.9.4.2 Press {RESET} to restore all parameters on the screen to their factory default states.
- 6.5.9.5 Press [SET] to accept the new data. This display will show the first SET screen.
- 6.5.9.6 Press [ESCAPE] to return to the primary screen.
- 6.5.10 {SPAN}
- 6.5.10.1 The analyser is calibrated using a known concentration of the gas of interest in a diluent of Nitrogen. The analyser needs to know the concentration given on a calibration cylinder's certificate.
- 6.5.10.2 The concentration value must be less than a value 15 % higher than the selected range and must be greater than 10 % of the range. As an example, if the 10 % range has been selected, a calibration value from 1 % up to 11.50 % can be used.
- 6.5.10.3 Press [SET]{SPAN} to display the SET SPAN screen.
- 6.5.10.4 Press [^], [v], [<], or [>] to select the value field. Press {EDIT}. Press the number keys to enter the value. Press {EDIT} to confirm.
- 6.5.10.5 Press [^], [v], [<], or [>] to select the range field. Press {EDIT}. Press [^] or [v] until the required range is displayed. Press {EDIT} to confirm.
- 6.5.10.6 To recover original settings :
- 6.5.10.6.1 Press {CLEAR} to restore the parameters to their original values or states when the screen was first invoked.
- 6.5.10.6.2 Press {RESET} to restore all parameters on the screen to their factory default states. Restoring factory defaults will clear any additional linearisation you may have applied to the analyser using the 'AK' commands. You will need to repeat the linearisation or download the tables.
- 6.5.10.7 Press [SET] to accept the new data. The display will show the first SET screen.
- 6.5.10.7.1 If the value is less than 10% or greater than 115% of the range an error message will be displayed. Use the [^], [v], [<], or [>] keys to select either the range or the value, press {EDIT} and re-enter the data. Press {EDIT} to confirm. If the data is now valid, the error message will be erased.
- 6.5.10.8 Press [ESCAPE] to return to the primary screen.
- 6.5.11 {T/C}
- 6.5.11.1 In addition to the normal response time of the gas path, additional digital time constants are used to filter any noise components. These can be changed to suit the application. Special (and unchangeable) time constants are used during calibration.
- 6.5.11.2 To conform to standard electronic definitions, the time constant is defined as the time taken for a step change to reach 63% of the change. In the gas analysis industry the 5% to 95% points are often used to determine the response time. Approximately three times the electrical time constant is required to go from 5 % to 95 % of a step change.
- 6.5.11.2.1 The Analyser has been shipped with time constants set to suit each range. In some cases, additional filtering may be required to 'average' a noisy concentration; in others, less filtering may be required to observe fast transitions in the concentration. In both cases it is a trade off between response time and noise. The time constants that the analyser was shipped with are reported on the analyser test results sheet.

- 6.5.11.2.2 Since the digital time constant is applied after the concentration has been measured, the response time cannot be faster than the time it takes for the concentration to travel down the gas path (both within and external to the analyser) to reach the detector. Setting the digital time constant to 0.1 (the minimum allowed) will produce the fastest response time that the analyser and its external plumbing will allow.
- 6.5.11.3 The time constant is entered in units of 0.1 seconds from 0.1 to 600 seconds. All ranges have individual time constants applied to them, even if they have been inhibited by the RANGE INHIBIT function. Time constants do not apply during calibration.
- 6.5.11.4 Press [SET]{T/C} to select the SET TIME CONSTANT screen. The display shows the time constant for each range.
- 6.5.11.5 Press [^], [v], [<], or [>] to select the time constant for a particular range. Press {EDIT}. Use the number keys to enter the time constant. Press {EDIT} to confirm.
- 6.5.11.6 To recover original settings :
- 6.5.11.6.1 Press {CLEAR} to restore the parameters to their original values or states when the screen was first invoked.
- 6.5.11.6.2 Press {RESET} to restore all parameters on the screen to their factory default states. Please note that the analyser will have been shipped with time constants set as recorded on the Test results sheet. Specified analyser performance is achieved with the time constants as recorded.
- 6.5.11.7 Press [SET] to accept the new data. The display will show the first SET screen.
- 6.5.11.8 Press [ESCAPE] to return to the primary screen.

## 7. LOGIC REMOTE CONTROL

### 7.1 Description

- 7.1.1 The analyser has four types of remote control.
- 7.1.1.1 LOCAL ONLY prevents serial or logic control and allows full control from the front panel..
- 7.1.1.2 SERIAL ONLY prevents front panel or logic control and allows the serial port to control the analyser.
- 7.1.1.3 LOGIC allows logic control to access those functions for which an enable line is active; all other functions are controlled from the front panel.
- 7.1.1.4 LOCAL allows :-
- 7.1.1.4.1 Front panel control unless serial port or logic control over-ride them.
- 7.1.1.4.2 Serial port control by sending an 'AK' SREM command. This prevents any front panel control or serial port control. The original control is restored when an 'AK' SMAN command is sent.
- 7.1.1.4.3 Logic control on any function whose enable line is active. Other functions are controlled from the front panel. An 'AK' SREM command will remove control from the logic lines and from the front panel until an 'AK' SMAN command is sent.
- 7.1.2 Disable SERIAL if you want to prevent the serial port gaining remote control. Choose LOCAL if you want both logic and the serial port to access the analyser. Use the [SET]{REM} menu to choose the type of control you want.
- 7.1.3 A computer with a digital I/O capability and running dedicated software, or a series of switches and indicators, can be used to control the most frequently required functions and display the analyser state. The control is not as comprehensive as that provided by serial remote control.
- 7.1.4 Range, gas path, autocal and sleep can be set. The readiness state, range, gas path, high and low alarm states, calibration progress and the analyser fault condition can be monitored.
- 7.1.5 Remote control must be enabled before remote commands can be accepted. This applies to both logic and serial commands. If the serial remote control is connected and the SREM command has been sent, the logic commands will be ignored. Sending the SMAN command will restore control to the logic inputs.
- 7.1.6 Logic inputs are coded for contact closure use. Inputs left open circuit are regarded as OFF. Only those functions required need be wired since the others will default to OFF. This type of coding is often called 'negative logic' because a 'Low' level is TRUE and a 'High' level is FALSE. Voltages from 5 V TTL or CMOS logic can be used to code the inputs. Refer to section 2.8 for input restrictions and to section 3.7 for wiring and typical interfacing methods.
- 7.1.7 Logic outputs are also coded in negative logic. A TRUE state is a 'low' voltage and a FALSE state is a 'high' voltage.
- 7.1.8 The range and gas path selections are encoded.

Equivalent Meanings	
True	False
0V	5V
Logic 1	Logic 0
Low	High

**Table 7 Logic Levels**

## 7.2 Range Control and Indication

7.2.1 Range is shown by the state of three output lines RO0, RO1, and RO2. They are encoded in binary using negative logic. Range is controlled by the state of three digital input lines RI0, RI1, and RI2. These are also coded in binary using negative logic. A further input REN (remote enable) must be held 'low' (TRUE) to enable range control. The codes are the same for both output and control and are given in Table 8.

Range	RI2 or RO2	RI1 or RO1	RI0 or RO0
1	Low	Low	Low
2	Low	Low	High
3	Low	High	Low
4	Low	High	High
5	Low	Low	Low
6	Low	Low	High

Table 8 Range Control Logic

## 7.3 Gas Path Control and Indication

7.3.1 Gas path is shown by the state of two output lines GPO0 and GPO1. They are encoded in binary using negative logic. Gas path is controlled by the state of two digital input lines GPIO and GPI1. These are also coded in binary using negative logic. A further input line GPEN (gas path enable) must be held 'low' (TRUE) to enable gas path control. The codes are the same for both output and control and are given in Table 9.

Gas Path	GPI1 or GPO1	GPI0 or GPO0
Sample	High	High
Zero	High	Low
Span	Low	High
Sample	Low	Low

Table 9 Gas Path Control Logic

## 7.4 Analyser Mode Control and Indication

7.4.1 These lines are not used in this analyser. They are only applicable to analysers with alternative modes of operation (i.e. secondary gas measurement from catalytic converters).

## 7.5 Calibration Control and Indication

7.5.1 Calibration is controlled by the ACAL (autocal) and GPEN (gas path enable) input lines. The progress through the calibration procedure is shown by the CIP (calibration in progress), READY, and CFail (calibration fail) output lines.

Gas Path	Calibration
Zero	Zero Only
Span	Span Only
Sample	Zero and Span

Table 10 Calibration Types

7.5.2 A calibration can be started by taking the ACAL input Low for a minimum period of two seconds then returning it High.

7.5.3 Taking the GPEN line Low disables the front panel {CAL} key in addition to the gas path selection keys. Calibration is then only possible from the ACAL input line. The calibration type depends on the gas path setting. Refer to Table 10.

7.5.4 A calibration can be stopped while in progress by taking the ACAL input Low for a minimum of two seconds the returning it High. The calibration details will not be updated.

7.5.5 While calibration is in progress, the CIP output will go Low and the READY output will go High. Calibration includes a time delay during which sample is selected and allowed to stabilise. The CIP output will go High and the READY output will go low after the delay.

7.5.6 If the calibration fails, the CFAIL output will go Low and remain there until a satisfactory calibration is obtained, or until the factory default values are restored.

## 7.6 Concentration Alarms

7.6.1 AL1 and AL2 are two alarm outputs. Each can be programmed to operate when the concentration is above (HIGH) or below (LOW) preset levels.

## 7.7 Sleep Mode Control

7.7.1 If the SLEEP input is taken Low, the analyser is placed into the 'standby' or 'sleep' mode. The full shutdown procedure will take several minutes while the sample lines are being purged. The pump will then be turned off. When the SLEEP input is released (taken High) the pump will be switched on and the analyser will measure from the selected gas path.

## 7.8 Fault Relay

7.8.1 Relay contacts are available for warning of a fault condition within the analyser. The FRCOM (common) contact will be connected to the FRNC (normally closed) contact when there is no power to the analyser and when there is a fault or error condition. The FRCOM (common) contact will be connected to the FRNO (normally open) contact when power is present and there is no fault or error condition detected.

## 8. SERIAL PORT REMOTE CONTROL

### 8.1 Description

- 8.1.1 The analyser has four types of remote control.
- 8.1.1.1 LOCAL ONLY prevents serial or logic control and allows full control from the front panel..
- 8.1.1.2 SERIAL ONLY prevents front panel or logic control and allows the serial port to control the analyser.
- 8.1.1.3 LOGIC allows logic control to access those functions for which an enable line is active; all other functions are controlled from the front panel.
- 8.1.1.4 LOCAL allows :-
- 8.1.1.4.1 Front panel control unless serial port or logic control over-ride them.
- 8.1.1.4.2 Serial port control by sending an 'AK' SREM command. This prevents any front panel control or serial port control. The original control is restored when an 'AK' SMAN command is sent.
- 8.1.1.4.3 Logic control on any function whose enable line is active. Other functions are controlled from the front panel. An 'AK' SREM command will remove control from the logic lines and from the front panel until an 'AK' SMAN command is sent.
- 8.1.2 Choose SERIAL ONLY if you want to prevent the control from the front panel at all times. Choose LOCAL if you want both logic and the serial port to access the analyser. Use the [SET]{REM} menu to choose the type of control you want.
- 8.1.3 A Signal Host, or other computer with at least one serial port and running dedicated software, can be used to control and interrogate the analyser. An RS232 serial port on the computer is connected to the serial port on the analyser and is used to transfer commands from the computer to the analyser, and the responses from the analyser to the computer. Up to eight analysers can be connected to the computer provided that there are enough serial ports and drivers.
- 8.1.4 The computer and analyser 'talk' to each other using a very structured protocol to ensure that commands cannot be misunderstood.
- 8.1.5 The remote control protocol follows the standard known as 'AK' which has been specified by the German automobile industry. It is based on the master/slave principle. The host computer is the master and the analysers are the slaves. Each analyser is connected to the host via an individual RS232 link. The host (master) issues a command 'packet' to an analyser (slave), the analyser processes the data and responds with an acknowledgement packet. The analyser cannot transmit any data to the host other than as an acknowledgement packet.
- 8.1.6 The analyser will always respond to any interrogation command. A command requiring control of the analyser will return the 'off-line acknowledgement' if serial remote control is not enabled.
- 8.1.7 When the analyser is in remote control, it will respond to both interrogation and control commands.
- 8.1.8 Ranges are identified in the 'AK' package by a number, with range 1 being the most sensitive and range 3 the least sensitive. To determine the actual concentrations, use the 'AK' AMBE command which returns a list of the full scale values (in ppm) of each range. You can use this list within your software to convert range numbers to range values.

8.1.9 There is an anomaly with the 'AK' pause (SPAU) and standby (STBY) commands when compared with typical interpretations. They are more applicable to system controllers than particular analysers. Confusion can arise with the normal (and Signal's) interpretation of STANDBY as meaning to go into a minimum state - not measuring. The actual 'AK' definitions as applied to analysers are :-

8.1.9.1 SPAU - The analyser is placed into a non-measuring state without depleting consumable items (pumps off, no flame for FID detectors, no ozone for NO<sub>x</sub> detectors, etc.).

8.1.9.2 STBY - The analyser is ready to measure sample gas present at the sample port.

## 8.2 General Packet Format

8.2.1 The general form of every packet is as follows:

8.2.2 <STX><x><CODE>[ .. data field .. ] <ETX>

8.2.3 Where:

<STX> Ascii STX

<ETX> Ascii ETX

<CODE> 4 Ascii Character Command code

x is a don't care byte that is read from DIP switches in the equipment.

8.2.4 All characters transmitted are standard ASCII printable characters except for the following:

<STX> Ascii STX (Decimal 2, or Hex 02)

<ETX> Ascii ETX (Decimal 3, or Hex 03)

<CR> Ascii carriage return (Decimal 13, or Hex 0D)

<LF> Ascii line feed (Decimal 10, or Hex 0A)

## 8.3 AK Command Packet

8.3.1 `Commands' and `data' packets are transmitted from the MASTER to a SLAVE.

8.3.2 <STX><x><CODE><space><K><n><space>[...data...]<ETX>

Where: K = Ascii character `K'

n = A single digit, 0-9, indicating channel number.

From the Signal Host to the Analysers, n is always 0.

## 8.4 AK Acknowledgement Packet

8.4.1 Acknowledgement messages are transmitted from a SLAVE to the MASTER as an acknowledgement to a command packet from the master.

8.4.2 The general form of an acknowledgement is

8.4.3 <STX><x><CODE><space><error>[ .. data field .. ]<ETX>

Where ...

space = Ascii space character.

error = A one byte indication of the state of the equipment.

Ascii `0' = No errors.

Ascii `1' - `9' = count of errors, increasing with each error and decreasing when each error is cleared. No more than nine errors can be reported. If the count shows 9 you may have nine or more errors.

CODE = The code of the command that was sent if it was understood. If received code was not understood, CODE in the acknowledgement will contain four question marks, i.e. ????.

Data field = Dependent upon the command issued.

8.4.4 There are various different acknowledgement packets.

8.4.4.1 OK Acknowledgement

8.4.4.1.1 If the received command was understood and processed by the slave the format of the acknowledgement is :-

<STX><x><CODE><space><error>[ data ]<ETX>

Where the data area contains the response to the command.

8.4.4.2 Off-line Acknowledgement

8.4.4.2.1 If the Analyser is `off-line' i.e. not in `remote' mode the acknowledgement is

<STX><x><CODE><space><error><space><K><0><space><0><F><ETX>

The command will be ignored.

8.4.4.3 Busy Acknowledgement

8.4.4.3.1 If the Analyser is `busy' i.e. not ready to accept and process a new command, the acknowledgement is

<STX><x><CODE><space><error><space><K><0><space><B><S><ETX>

The command will be ignored.

8.4.5 The Data Field

8.4.5.1 The data field may be from 0 to 99 characters long. Every data value will be preceded by a space. <CR> and <LF> characters may also be used as separators.

## 8.5 AK Codes

8.5.1 AAEG Return Full scale error "Range, Value, PPM Error, %Error"

data = NA

results = Mx xxxx.xxx xxxx.xxx xx for each range

Used by: Analyser

8.5.2 AANG Return Zero point error "Range, Value, PPM Error, %Error"

data = NA

results = Mx xxxx.xxx xxxx.xxx xx for each range

Used by: Analyser

8.5.3 AEMB Return Selected Range: Current analyser range

data = NA

results = Mx x=1 to 3 (7200) or 1 to 6 (7100)

Used by: Analyser



8.5.4	AKAK	Return Calibration gas concentration "Range, Cal Gas" data = NA results = Mx xxxx.xxx Used by: Analyser
8.5.5	AKON	Return Measured Value (as shown on the front panel display) data = NA results = ffff.ffff Used by: Analyser
8.5.6	AMBE	Return Range Full Scale "Range, FSD" data = NA results = MX xxxx.xx xxxx.xx ... in ppm for each range Used by: Analyser
8.5.7	AMBU	Return Auto-range Threshold "Range, Lower, Upper" data = NA results = Mx xxxx.xx xxxx.xx ... in ppm for each range Used by: Analyser
8.5.8	ASTF	Return Error Status: Equipment error code(s) data = NA results = x x x ... list of up to nine current error codes Used by: Analyser
8.5.9	AUKA	Return Uncorrected values "Range, uncorrected analogue value" data = NA results = Mx adc= $\pm$ xxxxx Used by: Analyser
8.5.10	EKAK	Set calibration gas concentration "Range, Concentration" data = Mx Span=xxxx.xx concentration in ppm results = NA Used by: Analyser
8.5.11	GKON	Return Measured Values data = NA results = tttt.tttt (CO or CO <sub>2</sub> ) Used by: Analyser
8.5.12	GRAD	Read average and alignment delay data = NA results = Av=X D0=X D1=X X= time in 0.1 seconds Used by: Analyser
8.5.13	GRAL	Read alarms (high, low, span, zero, temperature) data = NA results = LA=a HA=b ZA=c SA=d TA=e a=low concentration alarm status b=high concentration alarm status c= zero cal alarm status d=span cal alarm status e= temperature alarm status Used by: Analyser

8.5.14 GRAN Return Model, Serial No. and Gas Data  
 data = NA  
 results = Model=x Gases=x Serial#=xxxx

Used by: Analyser

Model Number	Model
0	Invalid
1	4000
2	3000
3	7000
6	8000

Table 12 Model Number Cross-Reference

Gas Data	Gas
0	Invalid
1	NO
2	NO <sub>x</sub>
3	NO <sub>2</sub>
4	CH <sub>4</sub>
5	THC
6	NMHC
7	CO <sub>2</sub>
8	CO
9	O <sub>2</sub>
10	Interference
11	TOT
12	NH <sub>3</sub>
13	N <sub>2</sub> O
14	SO <sub>2</sub>
15	R22

Table 11 Gas Number Cross-Reference

8.5.15 GRAV Read average, max and min concentrations  
 data = NA  
 results = AV=ffff.fff MX=gggg.gggg MN=hhhhh.hhhh  
 ffff.fff average reading.  
 gggg.ggg Minimum reading.  
 hhhh.hhh Maximum reading.

Used by: Analyser

8.5.16 GRCL Read calibration state  
 data = NA  
 results = CS=a ZS=b SS=c  
 a= calibration status  
 0=Not calibrating  
 1=Zero calibrating only  
 2=Span calibrating only  
 3=Zero calibrating before span  
 4=Not calibrating Basic data installed  
 b= zero calibration status  
 0=No zero calibration  
 1=Last Zero calibration Successful  
 2=Last Zero calibration Unsteady  
 3=Last Zero calibration Outside limits  
 c= Span calibration status  
 0=No Span calibration  
 1=Last Span calibration Successful  
 2=Last Span calibration Unsteady  
 3=Last Span calibration Outside limits

Used by: Analyser

8.5.17 GRCT Read the autocal interval  
 data = NA

- results = Atnnn (nnn in 0.1h units)  
Used by: Analyser
- 8.5.18 GRCT Return the Auto-cal time  
data = NA  
results = ATnnn - nnn in 6min (0.1h) units  
Used by: Analyser
- 8.5.19 GRLG Read the alarm limits  
data = Gx  
results = Gx Low=nnn High=nnn  
x= 0,1,2 for the gas, nnn= limit in ppm  
Used by: Analyser
- 8.5.20 GRMW Return Which Gas path SAMPLE, ZERO, SPAN  
data = MA  
results = me=x  
x=path 0=SAMPLE, 1=ZERO, 2=SPAN  
Used by: Analyser
- 8.5.21 GRPS Return the Pump state  
data = NA  
results = io=(0/1) 1=ON  
Used by: Analyser
- 8.5.22 GRSS Return System State  
data = NA  
results = Gx me=a Mb Conc=b AvC=c CS=d ZS=e SS=f LA=g  
HA=h ZA=i SA=j TA=k NF=l  
x = which gas number 0, 1, 2. see GRWG  
a = which gas route 0, 1, 2. see GRMW  
b = the instantaneous reading in ppm.  
c = The average reading in ppm.  
d = The calibration status. see GRCL  
e = The zero calibration status. see GRCL  
f = The span calibration status. see GRCL  
g = The low alarm status. see GRAL  
h = The high alarm status. see GRAL  
i = The zero alarm status. see GRAL  
j = The span alarm status. see GRAL  
k = The temperature alarm status. see GRAL  
l = The number of faults.  
Used by: Analyser
- 8.5.23 GRWG Return which gas  
data = NA  
results = Gn (n=gas number, always 0)  
Used by: Analyser
- 8.5.24 GSAC Abandon Calibration  
data = NA  
results = NA  
Used by: Analyser

8.5.25	GSAD	Set average and alignment delay  data = Av=X D0=X D1=X results = NA X= time in 0.1 seconds  Used by: Analyser	
8.5.26	GSCT	Set the autocal interval  data = ATnnn (nnn in 0.1h units) results = NA  Used by: Analyser	
8.5.27	GSLG	Set the alarm limits  data = G0 Low=nnn High=nnn nnn = limit in ppm results = NA  Used by: Analyser	
8.5.28	SARA	Auto-range Off  data = NA results = NA  Used by: Analyser	
8.5.29	SARE	Auto-range On  data = NA results = NA  Used by: Analyser	
8.5.30	SATK	Calibrate (equivalent to {SAMPLE}{CAL})  data = NA results = NA  Used by: Analyser/host	
8.5.31	SEGA	Set Span gas  data = NA results = NA  Used by: Analyser/host	
8.5.32	SEMB	Set Range  data = Mx results = NA  Used by: Analyser	x=0 for auto-range x=range number
8.5.33	SMAN	Disable Serial Remote Control  data = NA results = NA  Used by: Analyser/host/gas divider	
8.5.34	SMGA	Set Sample gas  data = NA results = NA  Used by: Analyser/host	
8.5.35	SNGA	Set Zero gas  data = NA results = NA  Used by: Analyser/host	

- 
- 8.5.36            SPAU        Pause  
                                 data = NA  
                                 results = NA  
                                 Used by: Analyser/host/gas divider
- 8.5.37            SREM        Enable Serial Remote Control  
                                 data = NA  
                                 results = NA  
                                 Used by: Analyser/host/gas divider
- 8.5.38            SRES        Reset  
                                 data = NA  
                                 results = NA  
                                 Used by: Analyser/host/gas divider
- 8.5.39            STBY        Standby (pump off, no gas path selected)  
                                 data = NA  
                                 results = NA  
                                 Used by: Analyser/host/gas divider

## 9. FAULT CODES

### 9.1 Information

- 9.1.1 The analyser reports the following codes on the serial port, when requested by a host using the 'AK' protocol, and displays them on the self check status page.
- 9.1.2 Health check codes for the three pressure sensors do not normally represent fault conditions. These codes mean that the analyser is not ready for operation.
- 9.1.3 Health check codes for P.S. and all self check codes normally represent unrecoverable faults requiring attention by our service department. In some cases it may be possible for you to replace a faulty PCB under instruction. Please contact our service department, or our local agent, and report the error codes present.

### 9.2 Self Check

- 9.2.1 E2 : WATCHDOG RESET
- 9.2.1.1 The internal device that checks for software malfunction has generated a reset. The analyser may be running correctly now. This condition can occur if mains transients, acute static discharge, or severe radio frequency interference cause the microprocessor to malfunction.
- 9.2.2 E3 : LINEARISATION BAD
- 9.2.2.1 The internal table containing linearisation data is corrupt.
- 9.2.3 E4 : EEPROM CORRUPT
- 9.2.3.1 The EEPROM containing factory configurable data is corrupt. It must be re-programmed.
- 9.2.4 E5: ADC CAL FAILURE
- 9.2.4.1 An analogue to digital converter failed to calibrate.
- 9.2.5 E6 : CORE CONFIGURATION BAD
- 9.2.6 E7 : CURRENT LINEARISATION BAD
- 9.2.7 E8 : BASIC LINEARISATION BAD
- 9.2.8 E9 : BBRAM BAD
- 9.2.8.1 The data stored in battery supported memory while the analyser is switched off is corrupt.
- 9.2.9 E64 : IIC ERROR, PIO #0
- 9.2.9.1 Failure to communicate with an internal input/output device.
- 9.2.10 E66 : IIC ERROR, PIO #1
- 9.2.10.1 Failure to communicate with an internal input/output device.
- 9.2.11 E68 : IIC ERROR, PIO #2
- 9.2.11.1 Failure to communicate with an internal input/output device.
- 9.2.12 E70 : IIC ERROR, PIO #3
- 9.2.12.1 Failure to communicate with an internal input/output device.

9.2.13	E72 : IIC ERROR, PIO #4
9.2.13.1	Failure to communicate with an internal input/output device.
9.2.14	E74 : IIC ERROR, PIO #5
9.2.14.1	Failure to communicate with an internal input/output device.
9.2.15	E76 : IIC ERROR, PIO #6
9.2.15.1	Failure to communicate with an internal input/output device.
9.2.16	E78 : IIC ERROR, PIO #7
9.2.16.1	Failure to communicate with an internal input/output device.
9.2.17	E144 : IIC ERROR, ADC #0
9.2.17.1	Failure to communicate with an analogue to digital converter.
9.2.18	E146 : IIC ERROR, ADC #1
9.2.18.1	Failure to communicate with an analogue to digital converter.
9.2.19	E160 : IIC ERROR, EEPROM
9.2.19.1	Failure to communicate with the memory device containing the factory configuration information.
9.2.20	E176 : IIC ERROR, RTC
9.2.20.1	Failure to communicate with the real time clock.
9.2.21	E240 : IIC UNKNOWN ERROR
9.2.21.1	An error in communication with one of the internal devices occurred.
9.2.22	E901 : RAM R/W ERROR
9.2.22.1	Failure to read or write to the internal random access memory.
9.2.23	E902 : EPROM CHECKSUM ERROR
9.2.23.1	The memory device containing the run-time software has a checksum error. It must be replaced.
9.2.24	E903 : EEPROM CHECKSUM ERROR
9.2.24.1	The memory device containing the factory configuration information has a checksum error. It must be re-programmed.
9.2.25	E904 : EEPROM WRITE ERROR
9.2.25.1	Failure to write to the memory device containing the factory configuration information.

### **9.3 Health Check**

9.3.1	E11 : P.S. STATUS
9.3.1.1	One of the internal power supplies is malfunctioning.
9.3.2	E21 : AMBIENT TEMPERATURE
9.3.2.1	The internal temperature is outside the acceptable range for the analyser. The analyser should only be used for short periods of time (about 30 mins) with this condition present.

9.3.3 E26 : REF

9.3.3.1 The internal reference pressure used to control cell, source and detector purge flows is not within working limits. Check the inlet pressure of the ZERO gas.

9.3.4 E27 : GAS FLOW

9.3.4.1 The gas flow is too high or too low. Span, zero, or sample gas sources should be turned on and their outlet pressure adjusted to keep the flow within the primary display flow markers.



## 10. TECHNICAL DESCRIPTION

### 10.1 Principle of Operation

10.1.1 Most gases absorb infra-red (heat) energy. The amount of absorption depends on the wavelength. Particular gases absorb well at particular wavelengths. Measuring the amount of absorption determines the amount of gas present in the sample. By selecting the wavelength it is possible to discriminate between one particular gas and any others.

10.1.2 If the gas of interest and a non absorbing gas are contained in separate sealed cells and the radiation is passed through each cell in turn, the radiation can be detected and a ratio obtained. If the sample is placed in the optical path it absorbs some of the radiation and alters the ratio. This difference between the ratios is measured and processed to produce the concentration value.

### 10.2 Sample System

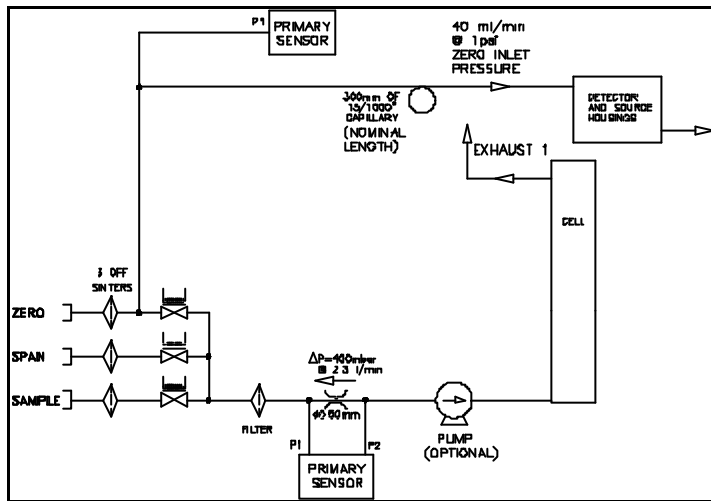

Figure 9 Flow Schematic Single Range Analyser

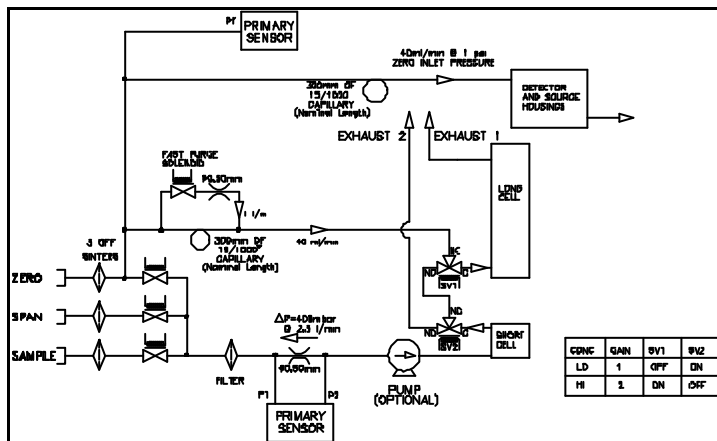

Figure 10 Flow Schematic Dual Range (Series) Analyser

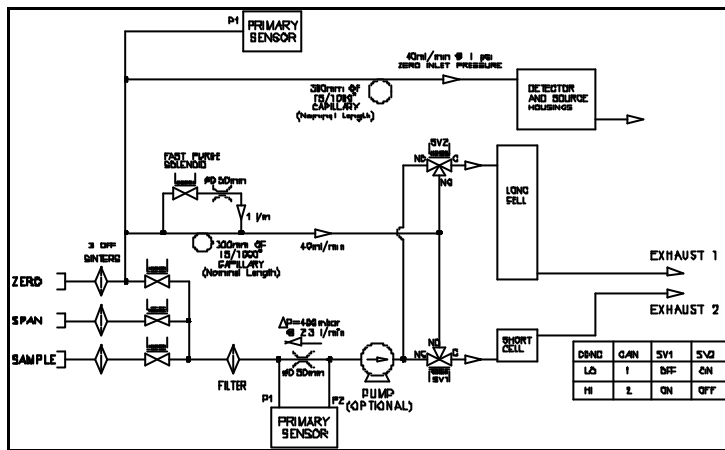

Figure 11 Flow Schematic Dual Range (Alternate) Analyser

- 10.2.1 Gas from the sample, zero, or span ports is passed through a filter. Flow is measured by the pressure drop across an orifice disk. All the sample flow passes through the sample cell.
- 10.2.2 A continuous small bleed of ZERO gas is passed through the detector and source housings to prevent absorption due to sample in the atmosphere.
- 10.2.3 There are two sample cells in the Dual Range analysers - a short one for the higher ranges and a longer one for greater sensitivity. Two solenoids determine which cell is used. Dual range analysers are configured as either **Dual Series**, where the Sample gas is passed through both cells on the lowest range and just the shorter cell on the higher range, or **Dual Alternate**, where the Sample gas is passed through one or other of the cells individually depending on the range selected. An unused cell is purged with ZERO gas. A timer controlled solenoid valve gives a fast purge immediately after cell selection. This drops to a small bleed to reduce ZERO gas consumption after the cell has been purged.

**10.3 Flow Control**

- 10.3.1 The unit incorporates as standard, solid state pressure and flow transducers which connect directly to the microprocessor unit for analyser health checking.
- 10.3.2 Use the [STATUS] pages to determine the 'health' of the analyser.

**10.4 Electronics**

- 10.4.1 The brain of the unit is the microprocessor electronics control unit. This very powerful system deals with all zero and span calibration requirements as well as the health checks on flow, temperatures, pressures, etc.
- 10.4.2 Digital conversion of the analogue input is carried out using 16 bits of A-D converter and 10 millisecond updates. This together with software reconstruction of the digital signal provide pure analogue chart recorder outputs across the whole range, fully corrected for zero and span calibration.
- 10.4.3 Simplicity has been the main objective in the design specification and operators will find the front panel controls very easy to use.

- 10.4.4 A clear back-lit LCD display provides the information to the user in a simple non-confusing style so that the measurements being taken can be confidently recorded without fear of errors from faulty interpretation.

## **10.5 User Interface**

- 10.5.1 The rear panel connections provide facilities for RS232 using the well known German AK protocol. A separate connector provide a contact closure style interface for all traditional activities such as range change, auto range, span/zero/sample, auto calibrate, and remote range ID. A further separate connector provides analogue outputs for chart recorders in both 0-10 Vdc and isolated 4-20 mA form, plus a 0-8 Vdc output for analogue range information.
- 10.5.2 You have the choice of manual control using the front panel keys, computer control using a serial port, or traditional digital logic or contact closure control.

## 11. ROUTINE MAINTENANCE

### 11.1 Introduction

11.1.1 The analyser requires little routine maintenance to keep it in good working order.

11.1.2 If the analyser is used infrequently, check calibration every time it is used.

### 11.2 Calibration

11.2.1 Regularly perform a full calibration. Allow the analyser to warm up fully before the calibration is checked. If the analyser is in continuous use, consider using the automatic calibration facility.

11.2.2 The frequency of calibration checks depends on the degree of accuracy expected from the analyser, the conditions under which it is being used, and its mode of operation. Calibration every week (168 hours) is recommended for normal operation under good conditions, and if the analyser is left running continuously. Once per day is recommended if the analyser is placed into standby mode or switched off overnight. You can calibrate as often as you need to confirm the accuracy of the analyser.

11.2.3 Refer to section 5.9 for instructions on setting up the analyser for calibration and information on the types of calibration that can be performed.

### 11.3 Password Release

11.3.1 In the unlikely event that you forget your password, or the password is not available to the maintenance engineer, the password may be displayed on the General Status page.

11.3.2 Remove the analyser from its rack or housing and place on a firm bench. Remove the eight screws securing the cover (four each side) and lift it clear.

11.3.3 Locate S1, an eight way DIL switch, on the CPU card which is the second one from the left within the electronic housing. It is accessible from the top without removing the board. Set position 3 to the CLOSED position.

11.3.4 The password will be visible on the General Status page when the analyser is switched on. Make a note of the number. Switch off and restore the switch to the OPEN position.

11.3.5 Replace the cover and secure with the screws.

11.3.6 The analyser operation is not affected in any other way when S1/3 is left in the CLOSED position.

## 12. ROUTINE SERVICING

### CAUTION

Live voltages are present within the analyser when the cover is removed. Do not attempt servicing if you do not have electrical service skills and the appropriate service facilities. Always ensure that the analyser is not connected to the mains supply when replacing parts.

#### 12.1 Policy

- 12.1.1 Full service manuals are normally only issued to distributors and agents, but can be purchased by customers if they wish to carry out their own servicing. All warranty will cease, however, if a customer carries out his own servicing during the warranty period unless special arrangements have been made in writing.
- 12.1.2 If you wish to carry out your own servicing, contact Signal, your local distributor, or agent.

### 13. WARRANTY

For a period of 24 months from the date on which an instrument is delivered to the Purchaser, Signal Group Ltd. (the 'Company') will exchange or repair at the Company's option any part or parts requiring replacement or repair by reason of defective workmanship or material. This warranty applies to all new instrumentation manufactured by and purchased from Signal Group Ltd. subject to these conditions of sale:

1. The Company's obligations are conditional upon the goods being properly packed and despatched by the Purchaser to the Company's Works with transportation, insurance and other charges prepaid by the Purchaser. There is no charge to the Purchaser for the cost of the materials or labour time expended by the Company in discharge of its warranties. If a site visit is requested a charge will be made to cover the travelling and at the Company's discretion, subsistence expenses.
2. The Company shall not be responsible for any defect which, in the opinion of the Company, was attributable to:
  - a) Wear and tear. Certain components are, by their nature, consumables, and are excluded from warranty. Such items include catalyst material, lamps, filters etc.
  - b) Any form whatsoever of improper use or maladjustment or damage caused by the Purchaser, his employees or anyone other than the Company's personnel.
  - c) Abnormal corrosive or abrasive conditions.
  - d) Lack of regular servicing and maintenance of the instrument by Signal Group Ltd. or an authorised representative. Regular servicing is required according to the relevant maintenance schedule or every six months after delivery to validate warranty, and will be chargeable at current rates.
  - e) Non-compliance with any instructions issued by the Company concerning the use and fitting of the instrument.
  - f) Damage arising from installation or use of the goods in unsuitable environmental conditions.
  - g) Faulty or irregular supply of electricity, air, water, gas or other site services.
  - h) Modifications by unauthorised personnel.
3. The Company shall not be responsible for any expense which the Purchaser may incur in removing, replacing or fitting any part.
4. Every other form of liability, including consequential loss, damage or cost, howsoever caused, is hereby expressly excluded except where such loss or damage arises from negligence of the Company or its servants.
5. This warranty is given in addition to your statutory rights.